

The page features a decorative graphic consisting of three overlapping blue circles of varying sizes, arranged in a diagonal line from the top right towards the bottom right. Thin blue lines extend from the top left and bottom right corners towards the center, intersecting the circles.

Notes on Sensors & Transducers

Brief description of sensors and its applications

By ER.SUSHANTA KUMAR JENA

ASST. PROF.SCE.

DEPT. OF ELECTRICAL ENGG

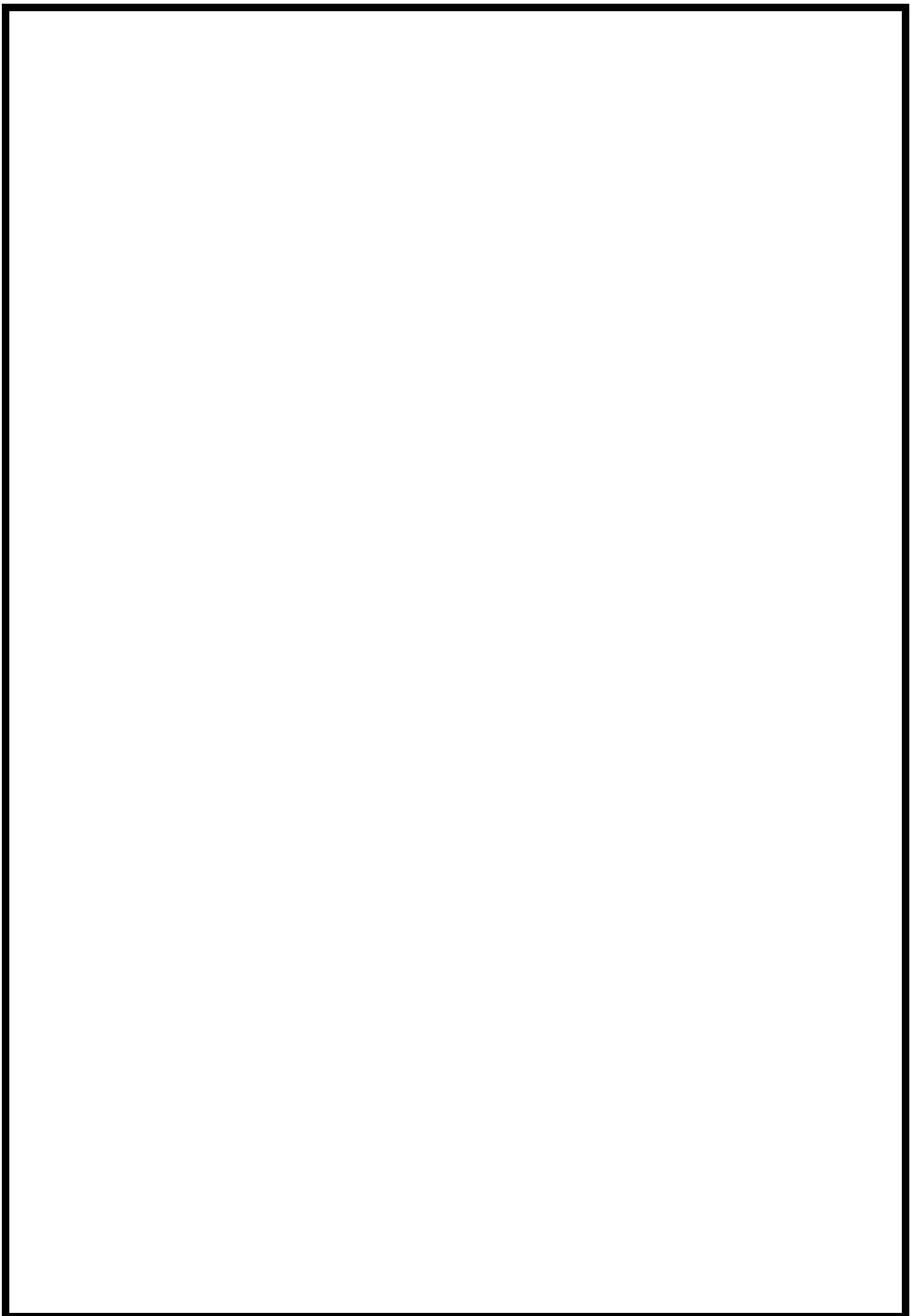

1. Introduction

For any closed loop industrial control system, there are three steps applying the input (reference value), control the process and feedback (negative feedback) that measuring the output and applying it back to the input stage. In the measuring stage we need special devices which can sense changes in the controlled physical quantity such devices are Sensors.

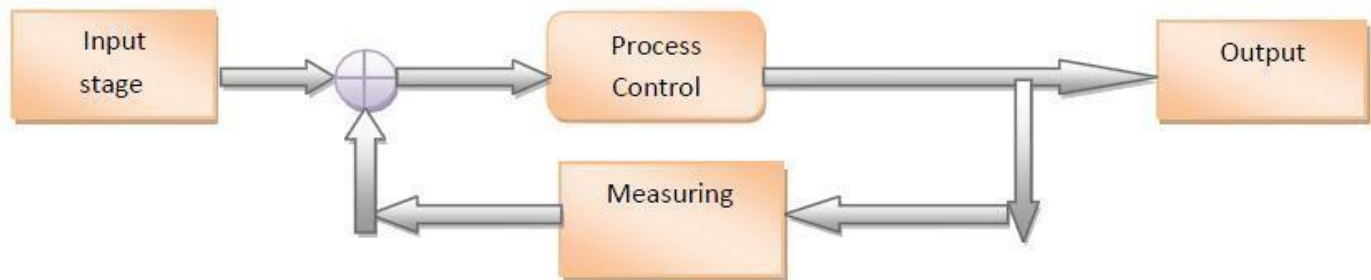

Figure (1.1): Simple control system.

A transducer is a device that converts one type of energy to another. The conversion can be to/from electrical, electro-mechanical, electromagnetic, photonic, photovoltaic, or any other form of energy. While the term transducer commonly implies use as a sensor/detector, any device which converts energy can be considered a transducer.

Transducers may be categorized by application: Sensor, actuator, or combination

Applications:

(a) Electromagnetic:

- Antenna - converts electromagnetic waves into electric current and vice versa.
- Cathode ray tube (CRT) - converts electrical signals into visual form
- Fluorescent lamp, light bulb - converts electrical power into visible light
- Magnetic cartridge - converts motion into electrical form
- Photodetector or Photoresistor (LDR) - converts changes in light levels into resistance changes
- Tape head - converts changing magnetic fields into electrical form
- Hall effect sensor - converts a magnetic field level into electrical form only.

(b) Electrochemical:

- pH probes
- Electro-galvanic fuel cell
- Hydrogen sensor

(c) Electromechanical:

- Electroactive polymers
- Galvanometer
- Microelectromechanical systems

- Rotary motor, linear motor
 - Vibration powered generator
 - Potentiometer when used for measuring position
 - Load cell converts force to mV/V electrical signal using strain gauge
 - Accelerometer
 - Strain gauge
 - String Potentiometer
 - Air flow sensor
 - Tactile sensor
- (d) Electrostatic:
- Electrometer
- (e) Photoelectric:
- Laser diode, light-emitting diode - convert electrical power into forms of light
 - Photodiode, photoresistor, phototransistor, photomultiplier tube - converts changing light levels into electrical form
- (f) Thermoelectric:
- RTD Resistance Temperature Detector
 - Thermocouple
 - Peltier cooler
 - Thermistor (includes PTC resistor and NTC resistor)
- (g) Electroacoustic:
- Loudspeaker, earphone - converts electrical signals into sound (amplified signal → magnetic field → motion → air pressure)
 - Microphone - converts sound into an electrical signal (air pressure → motion of conductor/coil → magnetic field → signal)
 - Pick up (music technology) - converts motion of metal strings into an electrical signal (magnetism → electricity (signal))
 - Gramophone pick-up - (air pressure → motion → magnetic field → signal)

A sensor is used to detect a parameter in one form and report it in another form of energy (usually an electrical and/or digital signal). For example, a pressure sensor might detect pressure (a mechanical form of energy) and convert it to electricity for display at a remote gauge.

An actuator accepts energy and produces movement (action). The energy supplied to an actuator might be electrical or mechanical (pneumatic, hydraulic, etc.). An electric motor and a loudspeaker are both transducers, converting electrical energy into motion for different purposes.

An actuator accepts energy and produces movement (action). The energy supplied to an actuator might be electrical or mechanical (pneumatic, hydraulic, etc.). An electric motor and a loudspeaker are both transducers, converting electrical energy into motion for different purposes.

A sensor is a device that measures a physical quantity and converts it into a signal which can be read by an observer or by an instrument. For example, a mercury-in-glass thermometer converts the measured temperature into expansion and contraction of a liquid which can be read on a calibrated glass tube. A thermocouple converts temperature to an output voltage which can be read by a voltmeter. For accuracy, all sensors need to be calibrated against known standards.

Sensors are used in everyday objects such as touch-sensitive elevator buttons (tactile sensor) and lamps which dim or brighten by touching the base. There are also innumerable applications for sensors of which most people are never aware.

.Applications include cars, machines, aerospace, medicine, manufacturing and robotics

A sensor is a device which receives and responds to a signal or stimulus. Here, the term "stimulus" means a property or a quantity that needs to be converted into electrical form. Hence, sensor can be defined as a device which receives a signal and converts it into electrical form which can be further used for electronic devices. A sensor differs from a transducer in the way that a transducer converts one form of energy into other form whereas a sensor converts the received signal into electrical .form only

A sensor's sensitivity indicates how much the sensor's output changes when the measured quantity changes. For instance, if the mercury in a thermometer moves 1 cm when the temperature changes by 1 °C, the sensitivity is 1 cm/°C. Sensors that measure very small changes must have very high sensitivities. Sensors also have an impact on what they measure; for instance, a room temperature thermometer inserted into a hot cup of liquid cools the liquid while the liquid heats the thermometer. Sensors need to be designed to have a small effect on what is measured, making the sensor smaller often improves this and may introduce other advantages. Technological progress allows more and more sensors to be manufactured on a microscopic scale as microsensors using MEMS technology. In most cases, a microsensor reaches a significantly higher speed and sensitivity compared with Macroscopic approaches .

To illustrate the place of sensors in a larger system, Fig. 1.2 shows a block diagram of a data acquisition and control device. An object can be anything: a car, space ship, animal or human, liquid, or gas. Any material object may become a subject of some kind of a measurement. Data are collected from an object by a number of sensors. Some of them (2, 3, and 4) are positioned directly on or inside the object. Sensor 1 perceives the object without a physical contact and, therefore, is called a *noncontact*

sensor. An example of such a sensor is a radiation detector and a TV camera. Even if we say –noncontact, we remember that energy transfer always occurs between any sensor and an object.

Sensor 5 serves a different purpose. It monitors internal conditions of a data acquisition system itself. Some sensors (1 and 3) cannot be directly connected to standard electronic circuits because of inappropriate output signal formats. They require the use of interface devices (signal conditioners). Sensors 1, 2, 3, and 5 are passive. They generate electric signals without energy consumption from the electronic circuits. Sensor 4 is active. It requires an operating signal, which is provided by an excitation circuit. This signal is modified by the sensor in accordance with the converted information. An example of an active sensor is a thermistor, which is a temperature-sensitive resistor. It may operate with a constant-current source, which is an excitation circuit. Depending on the complexity of the system, the total number of sensors may vary from as little as one (a home thermostat) to many thousands (a space shuttle). Electrical signals from the sensors are fed into a multiplexer (MUX), which is a switch or a gate. Its function is to connect sensors one at a time to an analog-to-digital (A/D) converter if a sensor produces an analog signal, or directly

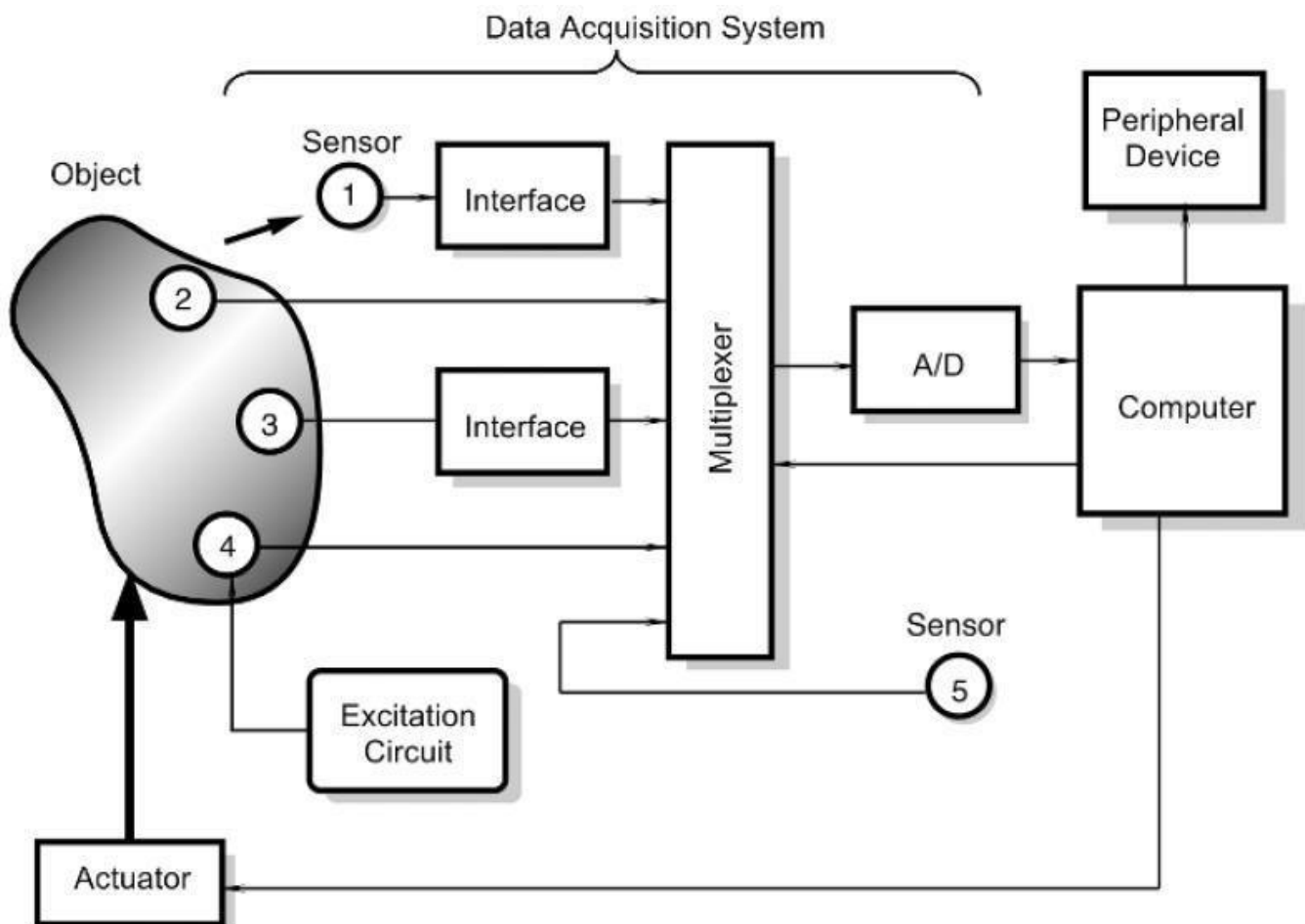

Figure (1.2): Positions of sensors in a data acquisition system. Sensor 1 is noncontact, sensors 2 and 3 are passive, sensor 4 is active, and sensor 5 is internal to a data acquisition system.

to a computer if a sensor produces signals in a digital format. The computer controls a multiplexer and an A/D converter for the appropriate timing. Also, it may send control

signals to the actuator, which acts on the object. Examples of actuators are an electric motor, a solenoid, a relay, and a pneumatic valve. The system contains some peripheral devices (for instance, a data recorder, a display, an alarm, etc.) and a number of components, which are not shown in the block diagram. These may be filters, sample-and-hold circuits, amplifiers, and so forth.

1.2 Classification of Sensors

All sensors may be of two kinds: **passive** and **active**. A passive sensor does not need any additional energy source and directly generates an electric signal in response to an external stimulus; that is, the input stimulus energy is converted by the sensor into the output signal. The examples are a thermocouple, a photodiode, and a piezoelectric sensor. Most of passive sensors are direct sensors as we defined them earlier. The active sensors require external power for their operation, which is called an *excitation signal*. That signal is modified by the sensor to produce the output signal.

The active sensors sometimes are called *parametric* because their own properties change in response to an external effect and these properties can be subsequently converted into electric signals. It can be stated that a sensor's parameter modulates the excitation signal and that modulation carries information of the measured value.

For example, a thermistor is a temperature-sensitive resistor. It does not generate any electric signal, but by passing an electric current through it (excitation signal), its resistance can be measured by detecting variations in current and/or voltage across the thermistor. These variations (presented in ohms) directly relate to temperature through a known function. Another example of an active sensor is a resistive strain gauge in which electrical resistance relates to a strain. To measure the resistance of a sensor, electric current must be applied to it from an external power source.

Depending on the selected reference, sensors can be classified into **absolute** and **relative**. An *absolute* sensor detects a stimulus in reference to an absolute physical scale that is independent on the measurement conditions, whereas a *relative* sensor produces a signal that relates to some special case. An example of an absolute sensor is a thermistor: a temperature-sensitive resistor. Its electrical resistance directly relates to the absolute temperature scale of Kelvin. Another very popular temperature sensor—a thermocouple—is a relative sensor. It produces an electric voltage that is function of a temperature gradient across the thermocouple wires. Thus, a thermocouple output signal cannot be related to any particular temperature without referencing to a known baseline. Another example of the absolute and relative sensors is a pressure sensor. An absolute-pressure sensor produces signal in reference to vacuum—an absolute zero on a pressure scale. A relative-pressure sensor produces signal with respect to a selected baseline that is not zero pressure (e.g., to the atmospheric pressure). Another way to look at a sensor is to consider all of its properties, such as what it measures (stimulus), what its specifications are, what physical phenomenon it is sensitive to, what conversion mechanism is employed, what material it is fabricated from, and what its field of application is.

Listing of common measured variables:

- Temperature
- Pressure

- Flow rate
- Composition
- Liquid level.

2. Temperature Sensors

(a) Oral Temperature

Everyone, sometime or another has had the need to find out their body temperature or the body temperature of a member of their family. An oral thermometer like the one shown in *Figure 2-1* was probably used. Liquid mercury inside of a glass tube expands and pushes up the scale on the tube as temperature increases. The scale is calibrated in degrees ($^{\circ}\text{F}$ —Fahrenheit in this case) of body temperature; therefore, the oral thermometer converts the physical quantity of temperature into a scale value that humans can read. The oral thermometer is a temperature sensor with mechanical scale readout.

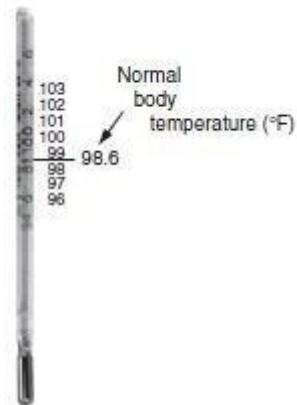

Figure (2.1): Oral Thermometer

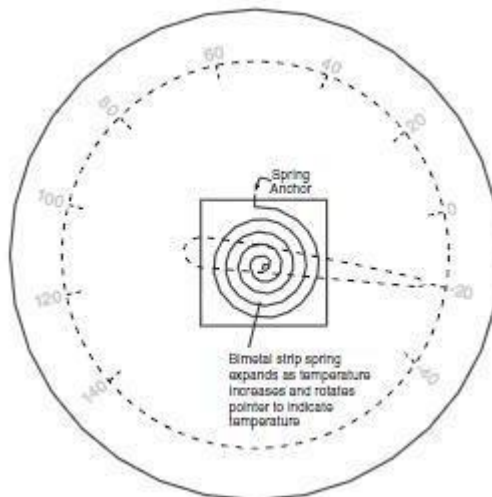

Figure (2.2): Rear view of bimetal strip thermometer

(b) Indoor/Outdoor Thermometer

Another temperature sensor is shown in *Figure 2-2*. It is a bimetal strip thermometer. Two dissimilar metals are bonded together in a strip that is formed into a spring. The metals expand differently with temperature; therefore, a force is exerted between them that expands the spring and rotates the needle as the temperature increases. The thermometer scale is calibrated to known temperatures—boiling water and freezing water. These points establish a

scale and the device is made into a commercial thermometer with Fahrenheit (°F) and/or Celsius (Centigrade— °C) scales. The one shown in *Figure 3-2* is for °F. The outdoor thermometer is another type of temperature sensor that converts the physical quantity of temperature into a meter reading easy for humans to see and interpret.

(c) Thermocouples

A thermocouple is another common temperature sensor. A place to find one is in a natural gas furnace in a home similar to that shown in *Figure 2-3*. It controls the pilot light for the burners in the furnace. The thermocouple is a closed tube system that contains a gas. The gas expands as it is heated and expands a diaphragm at the end of the tube that is in the gas control module.

The system works as follows: A button on the pilot light gas control module is pressed to open valve A to initially allow gas to flow to light the pilot light. The expanded diaphragm of the thermocouple system controls valve A; therefore, the button for the pilot light must be held until the thermocouple is heated by the pilot light so that the gas expands and expands the diaphragm. The expanded diaphragm holds valve A open; therefore, the pilot light button can be released because the pilot light heating the thermocouple keeps the gas expanded. Since the pilot light is burning, any demand for heat from the thermostat will light the burners and the house is heated until the demand by the thermostat is met. A thermocouple that puts out an electrical signal as temperature varies is shown in *Figure 2-4*. It is constructed by joining two dissimilar metals. When the junction of the two metals is heated, it generates a voltage, and the result is a temperature sensor that generates millivolts of electrical signal directly. The total circuit really includes a cold-junction reference, but the application uses the earth connection of the package as the cold reference junction.

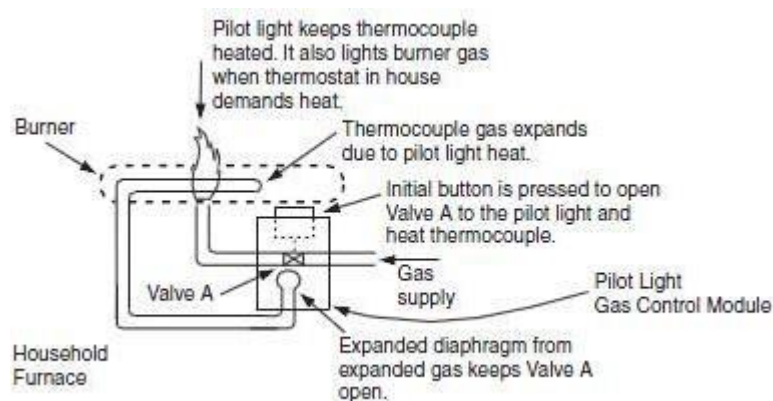

Figure (2.3): Rear view of bimetal strip thermometer

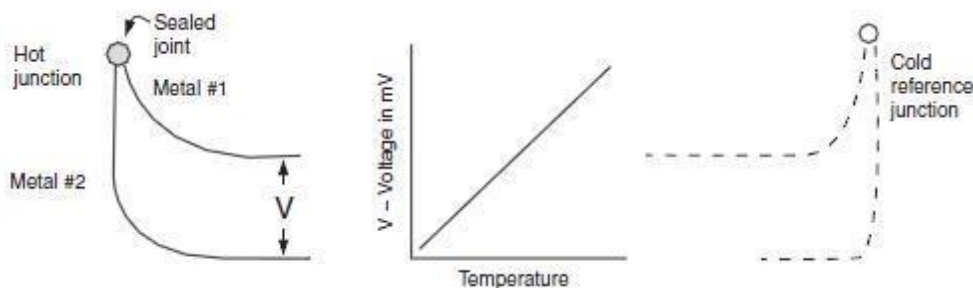

Figure (2.4): A bimetal thermocouple

There may be a need to amplify the output signal from the sensor, as shown in *Figure 3-5*, because the output voltage amplitude must be increased to a useful level.

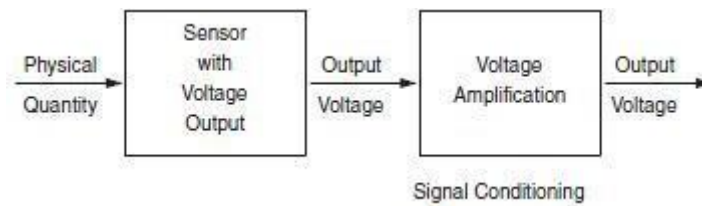

Figure (2.5): A sensor output signal may have to be increased to a useful level by amplification

(d) Thermistor

A thermistor is a resistor whose value varies with temperature. *Figure 2-5a* shows the characteristics of a thermistor readily available at RadioShack. Two circuits for the use of thermistors are shown in *Figure 2-5*. *Figure 2-5b* uses the thermistor in a voltage divider to produce a varying voltage output. *Figure 3-7c* uses a transistor to amplify the current change provided by the thermistor as temperature changes. In some micromachined thermistors, the resistance at 25°C is of the order of 10 kΩ. One of the disadvantages of using a thermistor is that its characteristics with temperature are not linear. As a result, in order to produce linear outputs, the nonlinearity must be compensated for.

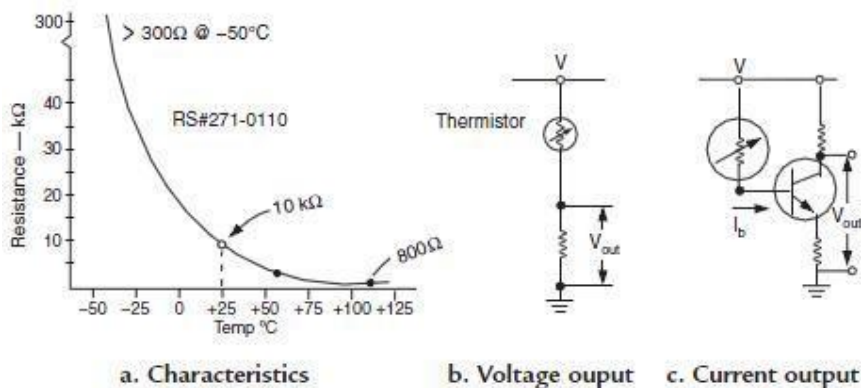

Figure (2.6): Thermistor temperature sensor

(e) Semiconductor P-N Junction Sensors

A semiconductor p-n junction in a diode and a bipolar transistor exhibits quite a strong thermal dependence. If the forward-biased junction is connected to a constant-current generator (Fig. 2.8a), the resulting voltage becomes a measure of the junction temperature (Fig. 2.9). A very attractive feature of such a sensor is its high degree of linearity. This allows a simple method of calibration using just two points to define a slope (sensitivity) and an intercept. The current-to-voltage equation of a p-n junction diode can be expressed as

$$I = I_0 \exp\left(\frac{qV}{2KT}\right)$$

Where I_0 is the saturation current, which is a strong function of temperature. It can be shown that the temperature-dependent voltage across the junction can be expressed as

$$V = \frac{E_g}{q} - \left(\frac{2KT}{q}\right) (\ln k - \ln I)$$

Where E_g is the energy band gap for silicon at 0 K (absolute zero), q is the charge of an electron, and K is a temperature-independent constant. When the junction is operated under constant-current conditions, the voltage is linearly related to the temperature

A diode sensor can be formed in a silicon substrate in many monolithic sensors which require temperature compensation. For instance, it can be diffused into a micromachined membrane of a silicon pressure sensor to compensate for temperature dependence of piezoresistive elements. An inexpensive yet precision semiconductor temperature sensor may be fabricated by using fundamental properties of transistors to produce voltage which is proportional to absolute temperature (in Kelvin). That voltage can be used directly or it can be converted into current. The relationship between base-emitter voltage (V_{be}) and collector current of a bipolar transistor is the key property to produce a linear semiconductor temperature sensor. Figure 16.22A shows a simplified circuit where Q_3 and Q_4 form the so-called current mirror. It forces two equal currents $I_{C1} = I$ and $I_{C2} = I$ into transistors Q_1 and Q_2 . The collector currents are determined by resistor R . In a monolithic circuit, transistor Q_2 is actually made of several identical transistors connected in parallel, (e.g., eight). Therefore, the current density in Q_1 is eight times higher than that of each of transistors Q_2 .

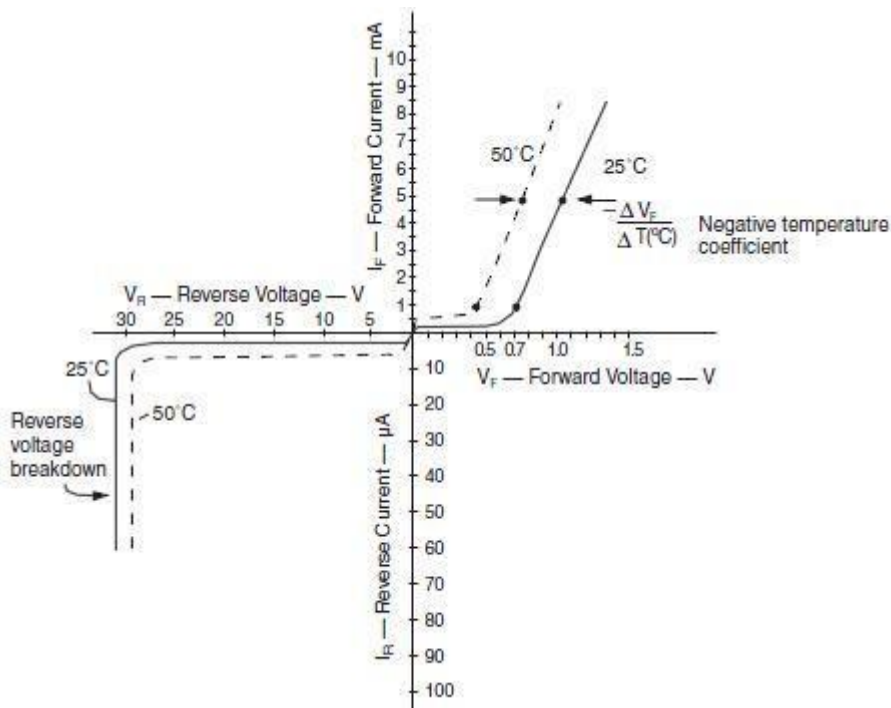

Figure (2.7): Silicon P-N Junction characteristics

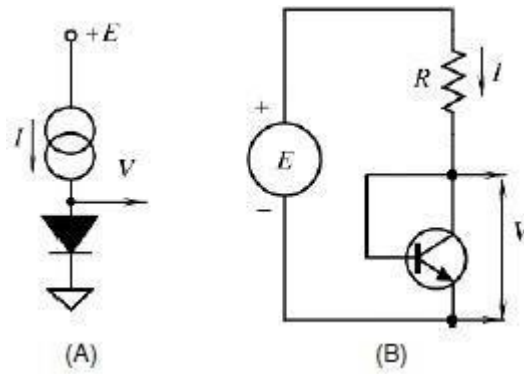

Figure (2.8): Voltage-to-temperature dependence of a forward-biased semiconductor junction under constant-current conditions.

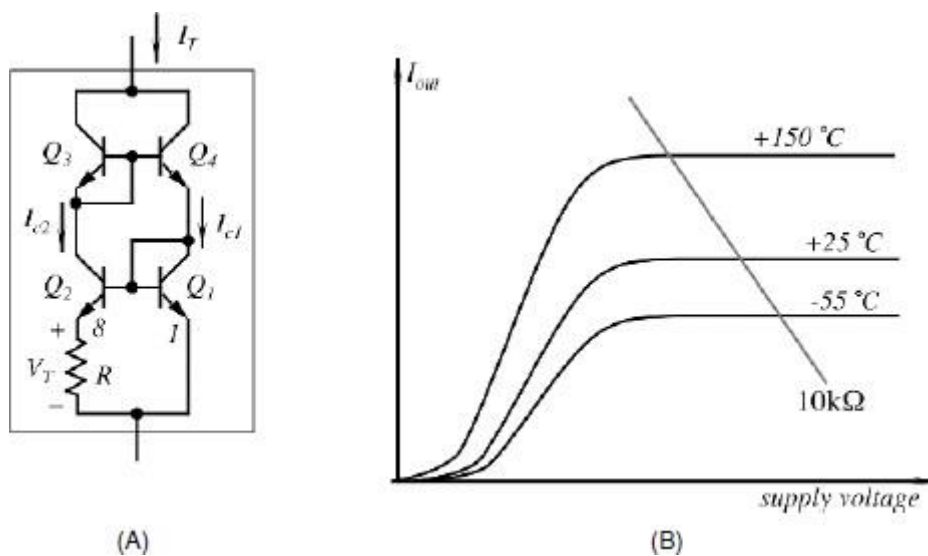

Figure (2.9): Simplified circuit for a semiconductor temperature sensor (A) and current-to-voltage curves (B).

(f) Acoustic Temperature Sensor

Under extreme conditions, temperature measurement may become a difficult task. These conditions include a cryogenic temperature range, high radiation levels inside nuclear reactors, and so forth. Another unusual condition is the temperature measurement inside a sealed enclosure with a known medium, in which no contact sensors can be inserted and the enclosure is not transmissive for the infrared radiation. Under such unusual conditions, acoustic temperature sensors may come in quite handy. An operating principle of such a sensor is based on a relationship between temperature of the medium and speed of sound. An acoustic temperature sensor (Fig. 2.10) is composed of three components: an ultrasonic transmitter, an ultrasonic receiver, and a gas-filled hermetically sealed tube. The transmitter and receiver are ceramic piezoelectric plates which are acoustically decoupled from the tube to assure sound propagation primarily through the enclosed gas, which, in most practical cases, is dry air. Alternatively, the transmitting and receiving crystals may be incorporated into a sealed enclosure with a known content whose temperature has to be measured; that is, an intermediate tube is not necessarily required in cases where the internal medium, its volume, and mass are held constant. When a tube is used, care should be taken to prevent its

mechanical deformation and loss of hermeticity under the extreme temperature conditions. A suitable material for the tube is Invar.

The clock of low frequency (near 100 Hz) triggers the transmitter and disables the receiver. The piezoelectric crystal flexes, transmitting an ultrasonic wave along the tube. The receiving crystal is enabled before the wave arrives at its surface and converts it into an electrical transient, which is amplified and sent to the control circuit. The control circuit calculates the speed of sound by determining the propagation time along the tube. Then, the corresponding temperature is determined from the calibration numbers stored in a look-up table. In another design, the thermometer may contain only one ultrasonic crystal which alternatively acts either as a transmitter or as a receiver. In that case, the tube has a sealed empty end. The ultrasonic waves are reflected from the end surface and propagate back to the crystal, which, before the moment of the wave arrival, is turned into a reception mode. An electronic circuit converts the received pulses into a signal which corresponds to the tube temperature. A miniature temperature sensor can be fabricated with the surface-acoustic-wave (SAW) and plate-wave (PW) techniques. The idea behind such a sensor is in the temperature modulation of some mechanical parameters of a timekeeping element in the electronic oscillator. This leads to the change in the oscillating frequency. In effect, such an integral acoustic sensor becomes a direct converter of temperature into frequency. A typical sensitivity is in the range of several kilohertz per degree Kelvin.

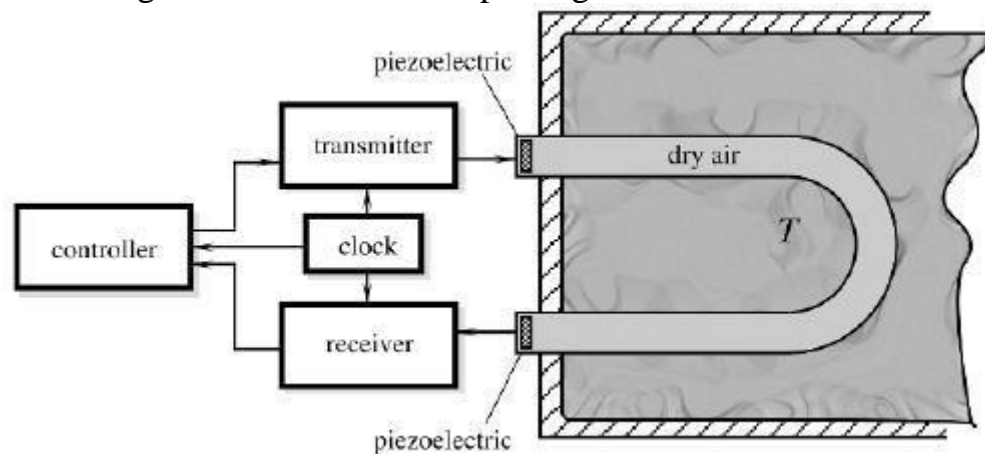

Figure (2.10): An acoustic thermometer with an ultrasonic detection system.

4. Pressure Sensors

(c) Piezoresistive Diaphragm

The physical construction of a pressure sensor is shown in *Figure 4-1a*. A fluid or gas under pressure is contained within a tube the end of which is covered with a thin, flexible diaphragm. As the pressure increases the diaphragm deflects. The deflection of the diaphragm can be calibrated to the pressure applied to complete the pressure sensor characteristics. Modern day semiconductor technology has been applied to the design and manufacturing of pressure sensors. A descriptive diagram is shown in *Figure 4-1b*. The thin diaphragm is micromachined from a silicon substrate on which a high-resistivity epitaxial layer has been deposited. The position of the diaphragm and its thickness on and in the substrate is defined using typical semiconductor techniques—form a silicon dioxide on the surface, coat it with photoresist, expose the photoresist with ultraviolet light through a mask

to define the diaphragm area, and etch away the oxide and silicon to the correct depth for the thin diaphragm. The assembly is then packaged to allow pressure to deflect the diaphragm. Using integrated circuit metallization techniques, the thin diaphragm, which changes resistance as it deflects, is connected into a Wheatstone bridge circuit as shown in *Figure 4-1c*. This provides a very sensitive, temperature compensated, measuring circuit. R_x in the circuit is the thin diaphragm resistance exposed to pressure. R_1 , R_2 , and R_3 are similarly micromachined resistors but they are not exposed to pressure. As temperature changes all the resistors change in like fashion because they are located very close together on the small semiconductor surface and have the same temperature coefficient. As a result, the sensor is temperature compensated. And since the resistors are very close together on the substrate, and are machined at the same time, they are very uniform in value.

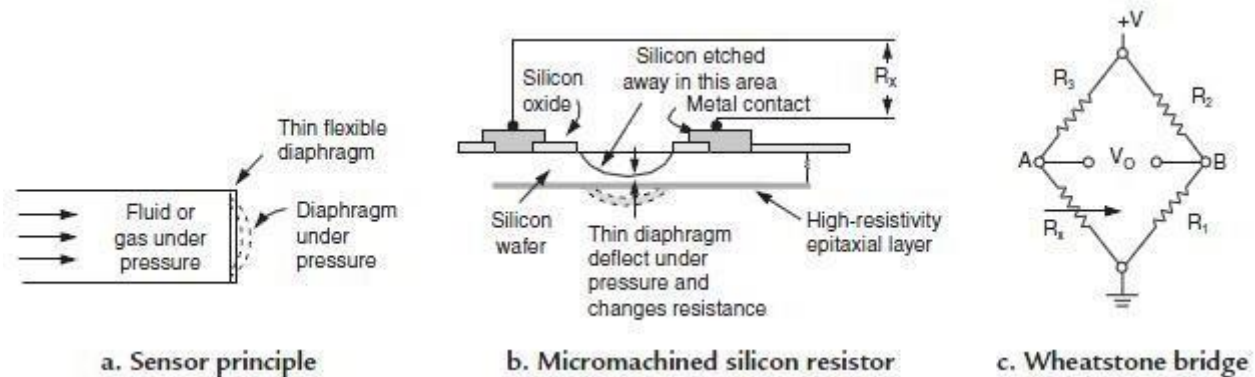

Figure (4.1): Micromachined pressure sensor

The Wheatstone Bridge

How does the Wheatstone bridge of *Figure 4-1c* work? The sensing voltage, V_O , is measured across the bridge from point A to point B. $V_O = 0$ when the bridge is balanced and is at its most sensitive measuring point. The circuit is analyzed as follows:

The voltage from point A to ground is:

$$V_A = R_x / (R_x + R_3) \times V$$

The voltage from point B to ground is:

$$V_B = R_1 / (R_1 + R_2) \times V$$

When the bridge is balanced, $V_A = V_B$ and

$$R_x / (R_x + R_3) \times V = R_1 / (R_1 + R_2) \times V$$

Cancelling V on both sides of the equation,

$$R_x / (R_x + R_3) = R_1 / (R_1 + R_2)$$

and transposing,

$$R_x (R_1 + R_2) = R_1 (R_x + R_3)$$

or

$$R_x R_2 = R_1 R_3$$

Because $R_1 R_x$ cancels on each side of the equation.

Therefore,

$$R_x = R_3 \times R_1 / R_2$$

At balance, the unknown resistance is equal to R_3 times the ratio of R_1 to R_2 . As R_x changes, the bridge will become unbalanced and a voltage, V_O , other than zero results. The voltage, V_O , is calibrated to the pressure to complete the sensor characteristics. Pressures from 0–500 psi (pounds per square inch) can be measured with such a pressure sensor. If R_1 , R_2 , and R_3 all equal 10 k Ω , when R_x varies from 10 k Ω to 20 k Ω , the output voltage will be

approximately from 10 mV to 20 mV per 1 kΩ of resistance change. One of the advantages of the silicon substrate sensors is that other integrated circuits can be in and on the silicon to provide signal conditioning to the voltage output, V_O .

(b) Capacitive Touch Diaphragm

The capacitive touch diaphragm sensor has the same micromachined structure as that shown in *Figure 4-1b*. However, its sensor principle, shown in *Figure 4-2a*, is different. The thin micromachined diaphragm is deflected as previously, but now the deflected diaphragm is designed to touch against a dielectric layer attached to a metal electrode. It forms a capacitor and as pressure increases, the capacitance between the diaphragm and the metal electrode, separated by the dielectric, increases linearly with pressure. The characteristic curve is shown in *Figure 4-2b*. Both of the micromachined sensors fabricated from silicon have -40° to $+135^\circ$ operation. For very extreme operating conditions of aircraft and automotive applications, there is a capacitive sensor with a ceramic diaphragm that deflects into a cavity. Its capacitance again increases with pressure.

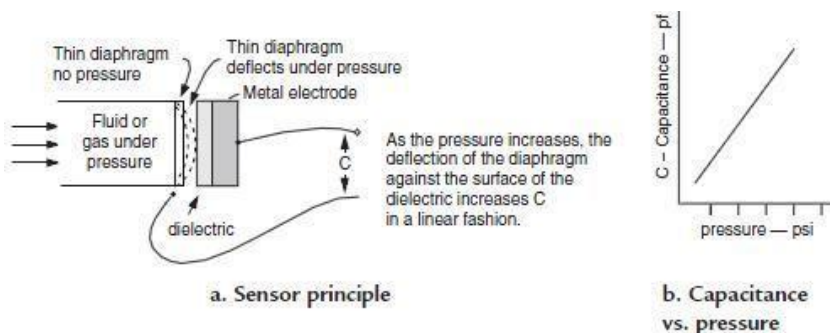

Figure (4.2): Capacitive touch pressure sensor

5. Light Sensors

(a) Photoresistor Sensor

A sensor that changes resistance as light is shined on it is made from Cadmium Sulfide (CdS), a semiconductor that is light sensitive. The characteristics of one available at RadioShack are shown in *Figure 5-1a*. In the dark with no light shining on it its resistance is greater than 0.5 MΩ. With one footcandle of light shining on it, its resistance is 1700 Ω, and the resistance is reduced to 100 Ω when 100 footcandles of light shine on it. Circuit applications are shown in *Figure 5-1b*. It can be used to change resistance values, to provide a sensor with a voltage output, or as a sensor supplying current to a load.

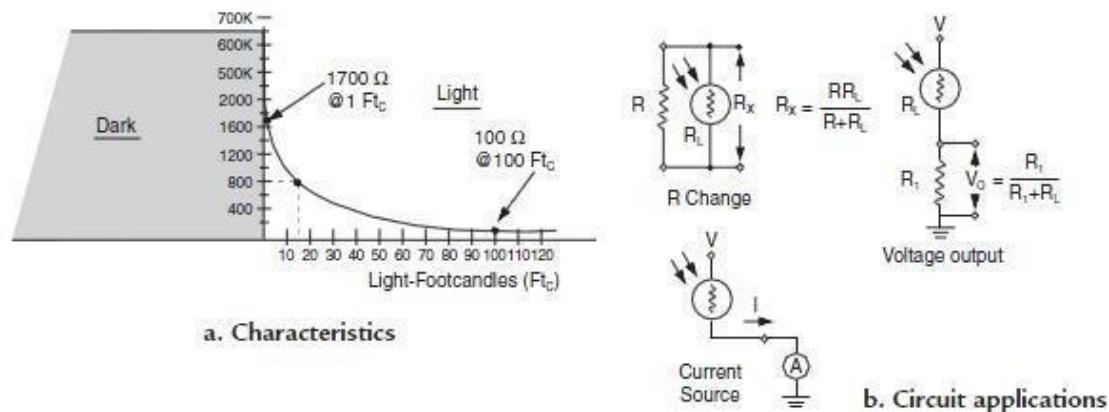

Figure (5.1): Photoresistor sensor

(b) Solar Cell

The solar cell is again a semiconductor PN junction that is light sensitive. It is made up of an N-type substrate, as shown in *Figure 5-2a*, with a very thin P region over the top surface. Most of the thin P surface is covered with narrow strips of metal that form the anode of the PN diode. A whole network of the narrow strips is interconnected on a silicon wafer to provide increased current output at the PN-junction voltage. The back of the silicon wafer is coated with metal to form the cathode of the diode. Light shining on the surface of the solar cell generates a maximum voltage of about 0.55V.

Under load, the average voltage output is approximately 0.5V. A common characteristic curve of voltage plotted against current is shown in *Figure 5-2b*. Solar cells can be applied in circuits, as shown in *Figure 5-2c*, by paralleling the cells for increased current output, or by connecting the cells in series for increased voltage output. Individual 2×4 cm solar cells are available at RadioShack that provide 300 mA at 0.55V, or there are enclosed modules that provide up to 6V at 50 mA.

A very common application for RV motorhomes is shown in *Figure 5-2d*. A solar panel is mounted on the roof of a motorhome and connected as shown to trickle charge the coach batteries when the RV is parked and under light load. Sunlight generates the voltage to supply the trickle current, which helps keep the batteries from discharging. Many units are available with power ratings from 2 to 50 watts.

(c) Phototransistors

Figure 5-3 allows a quick review of the operation of bipolar transistors, both NPN and PNP. Recall that for an NPN grounded emitter stage shown in *Figure 5-3a* the emitter is tied to ground, and for active operation, the base voltage is at +0.7V above ground and forward biases the base-emitter junction. The collector voltage is at a positive voltage above ground (+5V) so the collector base junction is reverse biased. When there is a current into the base, I_B , across the forward-biased base-emitter junction, a higher collector current, I_C , flows across the reverse-biased collector-base junction. There is a current gain through the transistor equal to the collector current divided by the base current, I_C/I_B . As shown in *Figure 5-3*, the current gain is h_{FE} . Everything is the same for the operation of the PNP transistor except the voltages are all negative with the emitter tied to ground. The h_{FE} is the same parameter as for the NPN. A phototransistor, a transistor designed to be activated by light, has the same basic operation as the NPN and PNP transistor described except it has no base connection. Its wide base junction is left exposed to light. Phototransistors are most sensitive to infrared light. The symbols and voltages are shown in *Figure 5-4a*. Light rays that impact the base-emitter junction effectively produce base current that activates the phototransistor. Through transistor action a larger collector current is produced. As shown by the characteristic curves of *Figure 5-4b*, more light intensity produces more collector current. A phototransistor can be coupled to the base of a driver transistor, as shown in *Figure 5-4c*, in order to make a linear driver or a logic-level driver. If a logic-level driver for ON-OFF applications is needed, R_{BIAS} and R_E are eliminated and the R_{ADJUST} used to set the desired sensitivity. R_{BIAS} and R_E set the operating point for Q_2 to obtain linear operation of the driver. *Figure 5-4d* shows a phototransistor sensing the presence of light to make a logic-level driver for a relay. The presence of light closes the normally-open contact to the center terminal to activate a connected circuit.

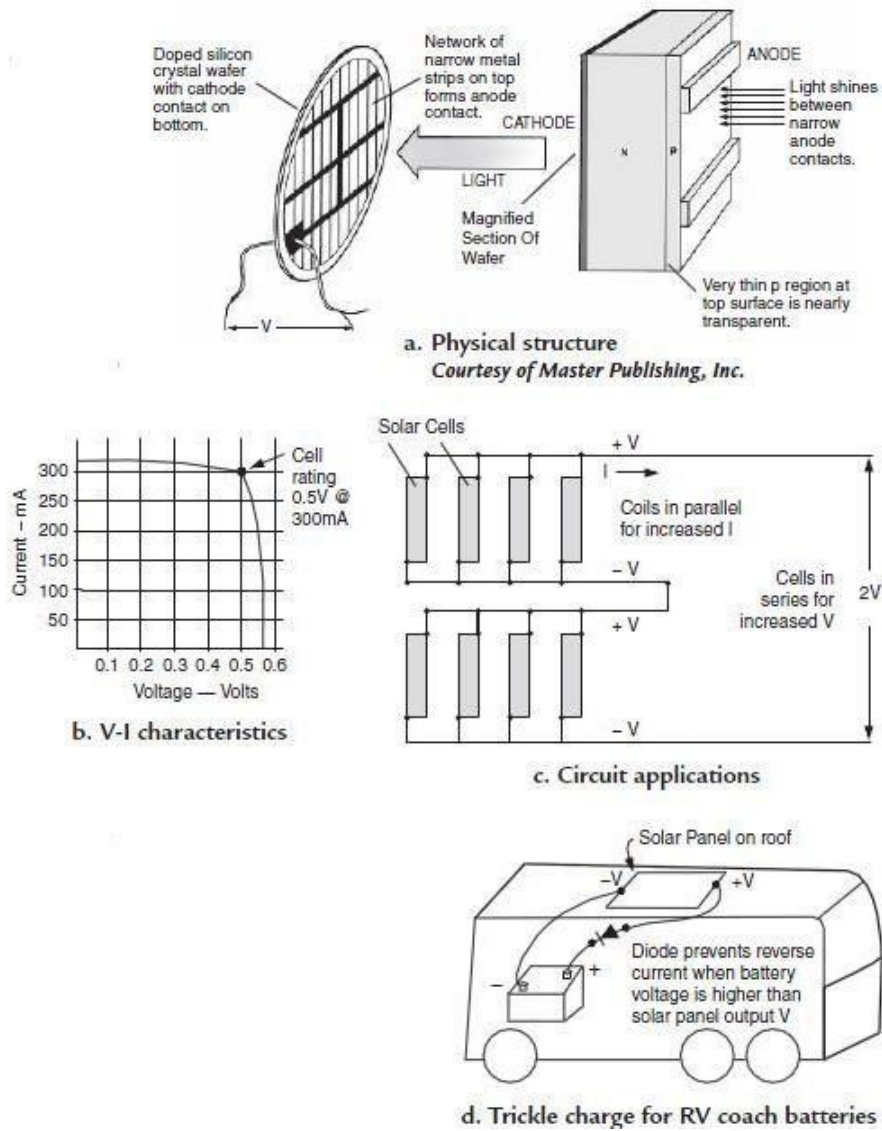

Figure (5.2): Solar Cell light sensor

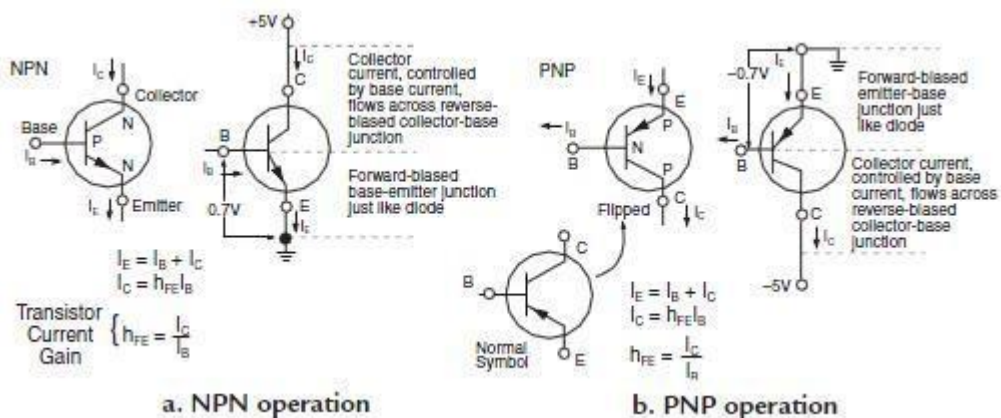

Figure (5.3): Bipolar transistor operation

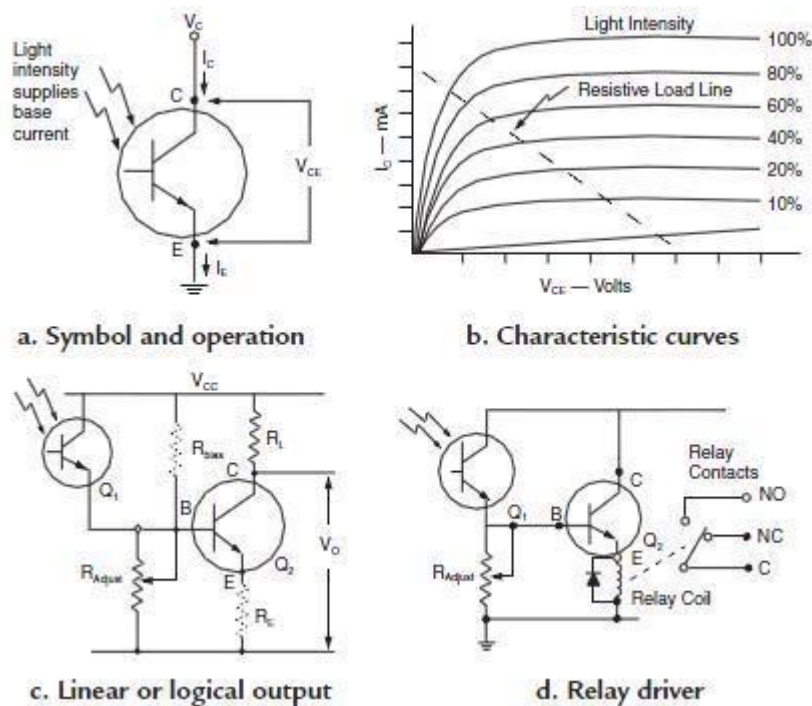

Figure (5.4): Phototransistor light sensor

6. Position, Displacement and Level Transducers

The measurement of position and displacement of physical objects is essential for many applications: process feedback control, performance evaluation, transportation traffic control, robotics, and security systems—just to name the few. By *position*, we mean the determination of the object's coordinates (linear or angular) with respect to a selected reference. *Displacement* means moving from one position to another for a specific distance or angle. In other words, a displacement is measured when an object is referenced to its own prior position rather than to another reference. Critical distance is measured by *proximity* sensors. In effect, a proximity sensor is a threshold version of a position detector. Position sensor is often a linear device whose output signal represents a distance to the object from a certain reference point. A proximity sensor, however, is a somewhat simpler device which generates the output signal when a certain distance to the object becomes essential for an indication. For instance, many moving mechanisms in process control and robotics use a very simple but highly reliable proximity sensor—the end switch. It is an electrical switch having normally open or normally closed contacts. When a moving object activates the switch by physical contact, the latter sends a signal to a control circuit. The signal is an indication that the object has reached the end position (where the switch is positioned). Obviously, such contact switches have many drawbacks, (e.g., a high mechanical load on a moving object and a hysteresis). A displacement sensor often is part of a more complex sensor where the detection of movement is one of several steps in a signal conversion. An example is a pressure sensor where pressure is translated into a displacement of a diaphragm, and the diaphragm displacement is subsequently converted into an electrical signal representing pressure. Position and displacement sensors are static devices whose speed response usually is not critical for the performance. We do not cover any sensors whose response is a function of time, which, by definition, are dynamic sensors. When designing or selecting position and displacement detectors, the following questions should be answered:

- How large is the displacement and of what type (linear, circular)?
- What resolution and accuracy are required?

- 3. What is the measured object made of (metal, plastic, fluid, ferromagnetic, etc.)?
- 4. How much space is available for mounting the detector?
- How much play is there in the moving assembly and what is the required detection range?
- What are the environmental conditions (humidity, temperature, sources of interference, vibration, corrosive materials, etc.)?
- How much power is available for the sensor?
- How much mechanical wear can be expected over the lifetime of the machine?
- What is the production quantity of the sensing assembly (limited number, medium volume, mass production)?
- What is the target cost of the detecting assembly?

A careful analysis will pay big dividends in the long term.

(a) Potentiometric Sensors

A position or displacement transducer may be built with a linear or rotary *potentiometer* or a *pot* for short. The resistance linearly relates to the wire length. Thus, by making an object to control the length of the wire, as it is done in a pot, a displacement measurement can be performed. Because a resistance measurement requires passage of an electric current through the pot wire, the potentiometric transducer is of an active type; that is, it requires an excitation signal, (e.g., dc current). A stimulus (displacement) is coupled to the pot wiper, whose movement causes the resistance change fig 6.1a In most practical circuits, the resistance measurement is replaced by a measurement of voltage drop. The voltage across the wiper of a linear pot is proportional to the displacement d :

$$V = E (d/D)$$

Where D is the full-scale displacement and E is the voltage across the pot (excitation signal). This assumes that there is no loading effect from the interface circuit. If there is an appreciable load, the linear relationship between the wiper position and the output voltage will not hold. In addition, the output signal is proportional to the excitation voltage applied across the sensor. This voltage, if not maintained constant, may be a source of error. It should be noted that a potentiometric sensor is a ratiometric device; hence the resistance of the pot is not a part of the equation. This means that its stability (e.g., over a temperature range) virtually has no effect on accuracy. For the low-power applications, high-impedance pots are desirable; however, the loading effect must be always considered. Thus, a good voltage follower is required.

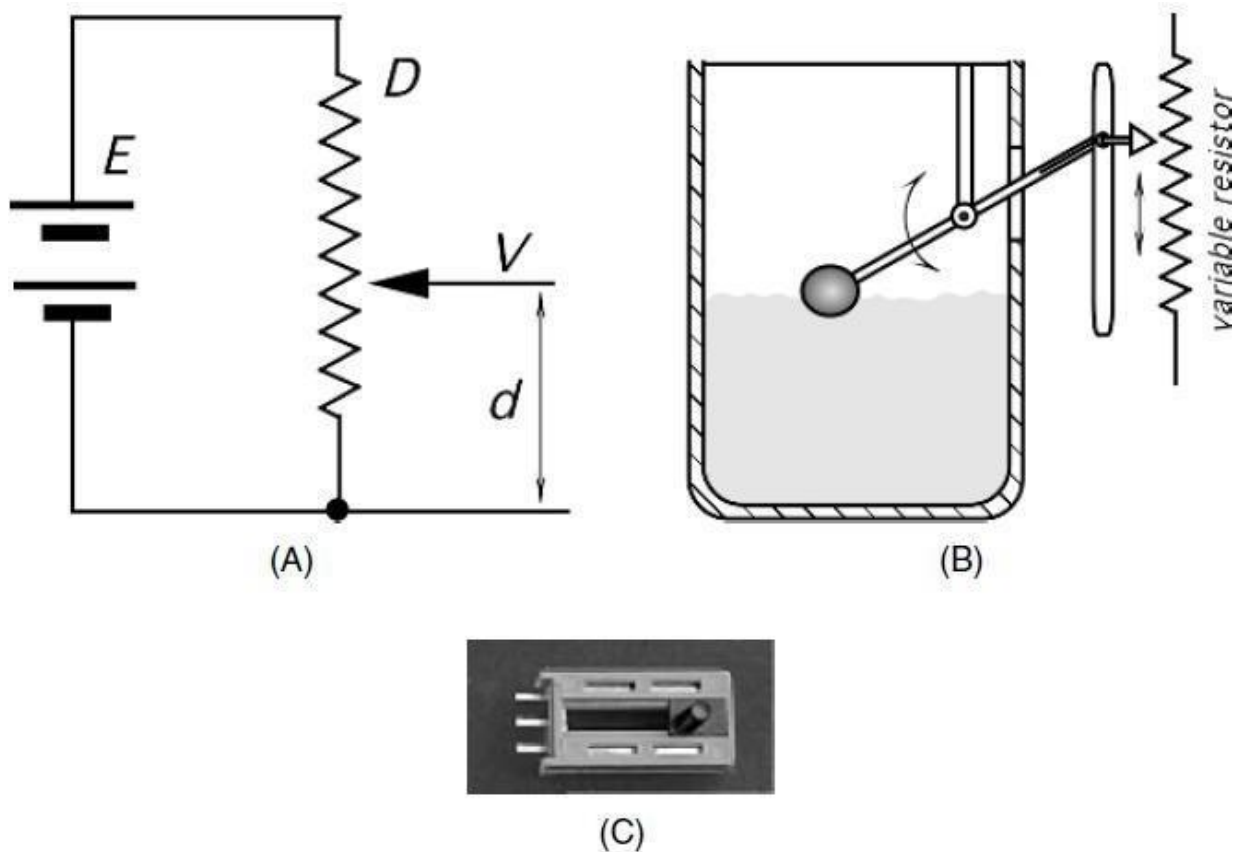

Figure (6.1): (A) Potentiometer as a position sensor; (B) gravitational fluid level sensor with a float; (C) linear potentiometer. (Courtesy of Piher Group, Tudela, Spain.)

The wiper of the pot is usually electrically isolated from the sensing shaft. Fig 6.2A shows one problem associated with a wire-wound potentiometer. The wiper may, while moving across the winding, make contact with either one or two wires, thus resulting in uneven voltage steps (Fig. 6.2B) or a variable resolution. Therefore, when the coil potentiometer with N turns is used, only the average Resolution n should be considered:

$$n = 100 / (N\%)$$

The force which is required to move the wiper comes from the measured object, and the resulting energy is dissipated in the form of heat. Wire-wound potentiometers are fabricated with thin wires having a diameter on the order of 0.01 mm. A good coil potentiometer can provide an average resolution of about 0.1% of FS (full scale), whereas the high-quality resistive film potentiometers may yield an infinitesimal resolution which is limited only by the uniformity of the resistive material and noise floor of the interface circuit. The continuous-resolution pots are fabricated with conductive plastic, carbon film, metal film, or a ceramic-metal mix which is known as *cermet*. The wiper of the precision potentiometers is made from precious metal alloys. Displacements sensed by the angular potentiometers range from approximately 10° to over 3000° for the multiturn pots (with gear mechanisms). Although quite useful in some applications, potentiometers have several drawbacks:

1. Noticeable mechanical load (friction)
2. Need for a physical coupling with the object
3. Low speed

4. Friction and excitation voltage cause heating of the potentiometer
5. Low environmental stability

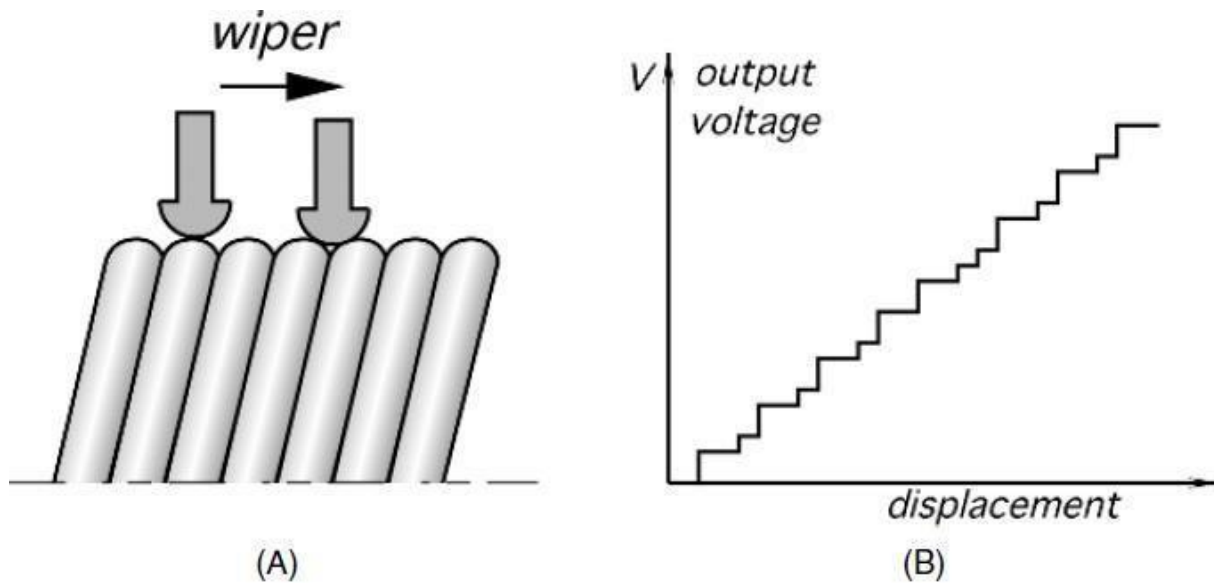

Figure (6.2): Uncertainty caused by a wire-wound potentiometer: (A) a wiper may contact one or two wires at a time; (B) uneven voltage steps.

(b) Gravitational Sensors

A well-known, popular gravitational-level transducer is used in a toilet tank. The transducer's main element is a float—a device whose density is lower than that of water. In most tanks, it is directly coupled to a water valve to keep it either open or shut, depending on how much water the tank holds. The float is a detector of the position of the water surface. For the measurement purposes, the float can be coupled to a position transducer, such as a potentiometric, magnetic, capacitive, or any other direct sensor (Fig. 6.1B). It should be noted that the gravitational sensor is susceptible to various interfering forces, resulting from friction and acceleration. Obviously, such a sensor will not work whenever gravity is altered or absent. A space station or a jet is not an appropriate place for such a sensor. *Inclination detectors*, which measure the angle from the direction to the Earth's center of gravity, are employed in road construction, machine tools, inertial navigation systems, and other applications requiring a gravity reference. An old and still quite popular detector of a position is a mercury switch (Figs. 6.3a and 6.3b). The switch is made of a nonconductive (often glass) tube having two electrical contacts and a drop of mercury. When the sensor is positioned with respect to the gravity force in such a way that the mercury moves away from the contacts, the switch is open. A change in the switch orientation causes the mercury to move to the contacts and touch both of them, thus closing the switch. One popular application of this design is in a household thermostat, in which the mercury switch is mounted on a bimetal coil which serves as an ambient-temperature sensor. Winding or unwinding the coil in response to room temperature affects the switch's orientation. Opening and closing the switch controls a heating/cooling system. An obvious limitation of this design is it's an on-off operation (a bang-bang controller in the engineering jargon). A mercury switch is a threshold device, which snaps when its rotation angle exceeds a predetermined value. To measure angular displacement with higher resolution, a more complex sensor is required. One elegant design

is shown in Fig. 6.3C. It is called the *electrolytic tilt sensor*. A small slightly curved glass tube is filled with a partly conductive electrolyte. Three electrodes are built into the tube: two at the ends, and the third electrode at the center of the tube. An air bubble resides in the tube and may move along its length as the tube tilts. Electrical resistances between the center electrode and each of the end electrodes depend on the position of the bubble. As the tube shifts away from the balance position, the resistances increase or decrease proportionally. The electrodes are connected into a bridge circuit which is excited with an ac current to avoid damage to the electrolyte and electrodes. A more advanced inclination sensor employs an array of photodetectors. The detector is useful in civil and mechanical engineering for the shape measurements of complex objects with high resolution. Examples include the measurement of ground and road shapes and the flatness of an iron plate, which cannot be done by conventional methods. The sensor (Fig. 6.4a) consists of a light-emitting diode (LED) and a hemispherical spirit level mounted on a p-n-junction photodiode array. A shadow of the bubble in the liquid is projected onto the surface of the photodiode array. When the sensor is kept horizontal, the shadow on the sensor is circular, as shown in Fig. 6.4B, and the area of the shadow on each photodiode of the array is the same. However, when the sensor is inclined, the shadow becomes slightly elliptic, as shown in Fig. 6.4C, implying that the output currents from the diodes are no longer equal. In a practical sensor, the diameter of the LED is 10 mm and the distance between the LED and the level is 50 mm, and the diameters of the hemispherical glass and the bubble are 17 and 9 mm, respectively. The outputs of the diodes are converted into digital form and calibrated at various tilt angles. The calibration data are compiled into look-up tables which are processed by a computing device. By positioning the sensor at the cross point of the lines drawn longitudinally and latitudinally at an interval on the slanting surface of an object, X and Y components of the tilt angle can be obtained and the shape of the object is reconstructed by a computer.

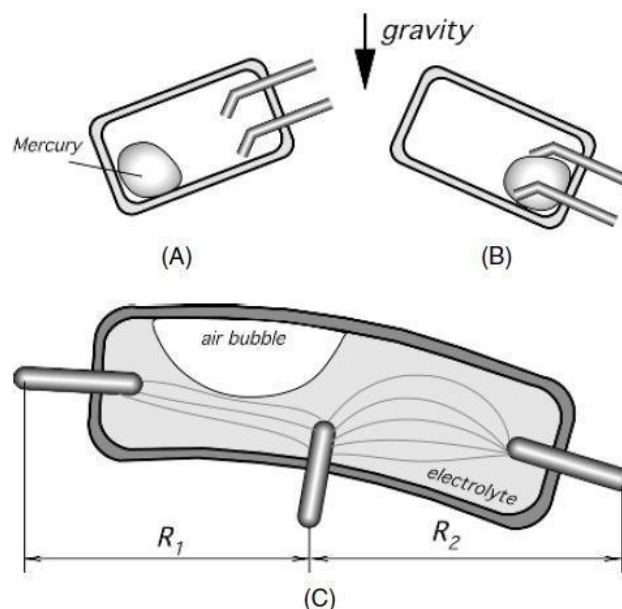

Figure (6.3): Conductive gravitational sensors: (A) mercury switch in the open position; (B) mercury switch in the closed position; (C) electrolytic tilt sensor.

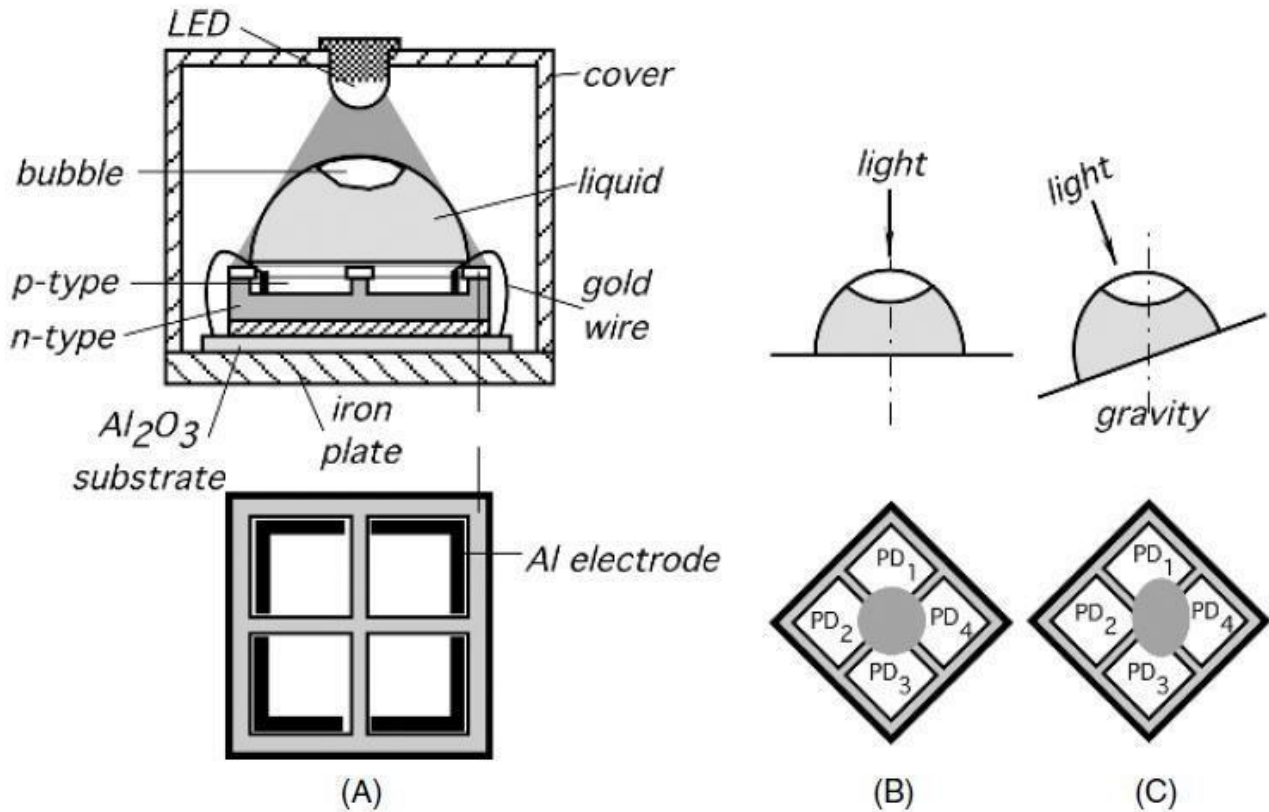

Figure (6.4): Optoelectronic inclination sensor: (A) design; (B) a shadow at a horizontal position; (C) a shadow at the inclined position.

(c) Capacitive Sensors

The capacitive displacement sensors have very broad applications, they are employed directly to gauge displacement and position and also as building blocks in other sensors where displacements are produced by force, pressure, temperature, and so forth. The ability of capacitive detectors to sense virtually all materials makes them an attractive choice for many applications. The operating principle of a capacitive gauge, proximity, and position sensors is based on either changing the geometry (i.e., a distance between the capacitor plates) or capacitance variations in the presence of conductive or dielectric materials. When the capacitance changes, it can be converted into a variable electrical signal. As with many sensors, a capacitive sensor can be either mono-polar (using just one capacitor) or differential (using two capacitors), or a capacitive bridge can be employed (using four capacitors). When two or four capacitors are used, one or two capacitors may be either fixed or variable with the opposite phase.

As an introductory example consider three equally spaced plates, each of area A (Fig 6.5a). The plates form two capacitors C_1 and C_2 . The upper and lower plates are fed with the out-of-phase sine-wave signals; that is, the signal phases are shifted by 180° . Both capacitors nearly equal one another and thus the central plate has almost no voltage because the currents through C_1 and C_2 cancel each other. Now, let us assume that the central plate moves downward by a distance X (Fig. 6.5b). This results in changes in the respective capacitance values:

$$C_1 = \epsilon \frac{A}{X_0 + X}$$

$$C_2 = \epsilon \frac{A}{X_0 - X}$$

And the central plate signal increases in proportion to the displacement and the phase of that signal is an indication of the central plate direction—up or down. The amplitude of the output signals is

$$V_{out} = V_0 \left(-\frac{X}{X_0 + x} + \frac{\Delta C}{C} \right)$$

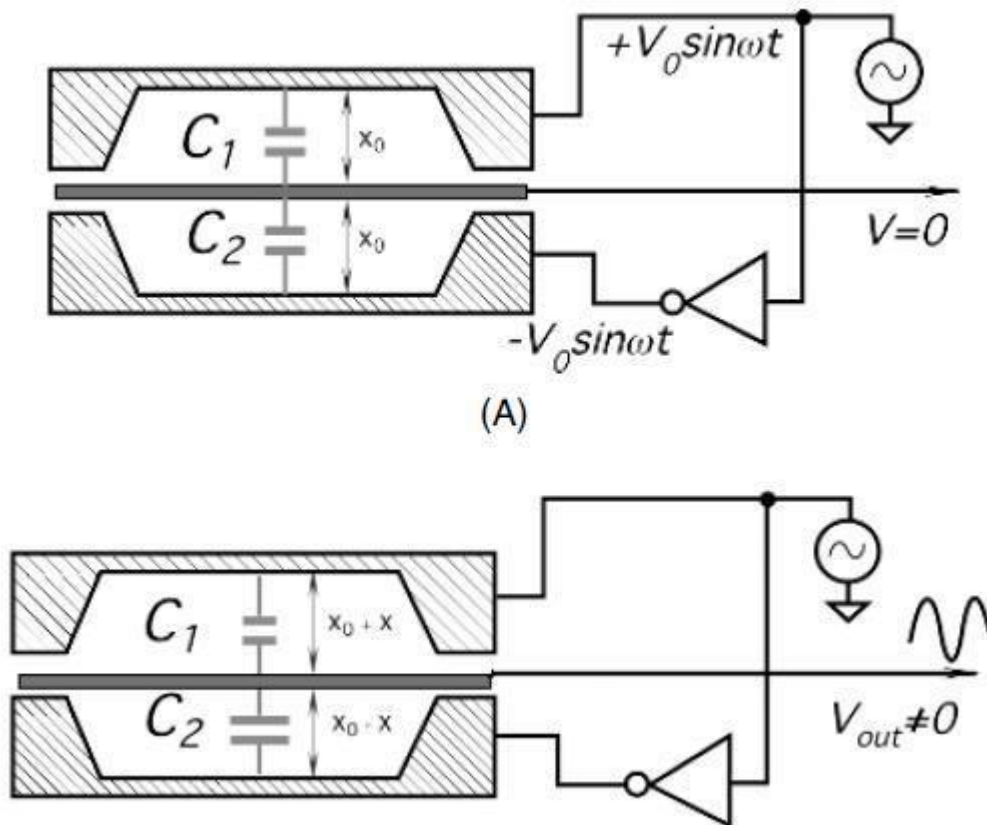

Figure (6.5): Operating principle of a flat plate capacitive sensor A-balanced position; B-disbalanced position

As long as $X \ll X_0$, the output voltage may be considered a linear function of displacement. The second summand represents an initial capacitance mismatch and is the prime cause for the output offset. The offset is also caused by the fringing effects at the peripheral portions of the plates and by the so-called electrostatic force. The force is a result of the charge attraction and repulsion applied to the plates of the sensor, and the plates behave like springs. In many practical applications, when measuring distances to an electrically conductive object, the object's surface itself may serve as the capacitor's plate. The design of a monopolar capacitive sensor is shown in Fig. 6.6, where one plate of a capacitor is connected to the central conductor of a coaxial cable and the other plate is formed by a target (object).

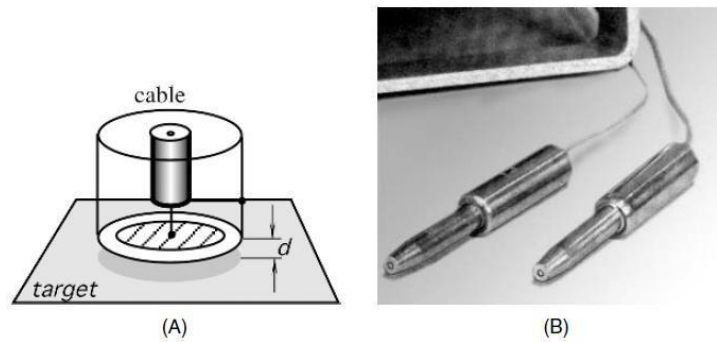

Figure (6.6): A capacitive probe with a guard ring: (A) cross-sectional view; (B) outside view.

(Courtesy of ADE Technologies, Inc., Newton, MA.)

Note that the probe plate is surrounded by a grounded guard to minimize a fringing effect and improve linearity. A typical capacitive probe operates at frequencies in the 3-MHz range and can detect very fast-moving targets, as a frequency response of a probe with a built-in electronic interface is in the range of 40 kHz. A capacitive proximity sensor can be highly efficient when used with the electrically conductive objects. The sensor measures a capacitance between the electrode and the object. Nevertheless, even for the nonconductive objects, these sensors can be employed quite efficiently, although with a lower accuracy. Any object, conductive or nonconductive, that is brought in the vicinity of the electrode, has its own dielectric properties that will alter the capacitance between the electrode and the sensor housing and, in turn, will produce the measurable response. To improve sensitivity and reduce fringing effects, the mono-polar capacitive sensor may be supplied with a driven shield. Such a shield is positioned around the non-operating sides of the electrode and is fed with the voltage equal to that of the electrode. Because the shield and the electrode voltages are in phase and have the same magnitude, no electric field exists between the two and all components positioned behind the shield have no effect on the operation. The driven-shield technique is illustrated in Fig. 6.7.

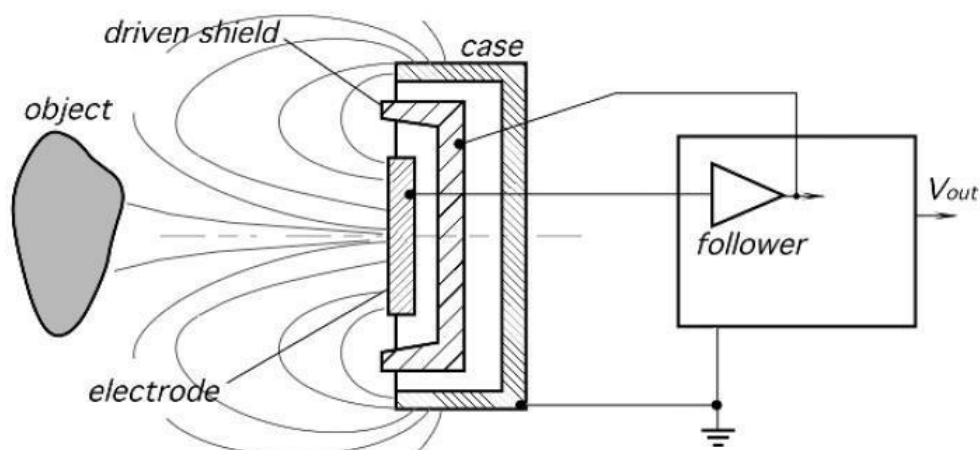

Figure (6.7): Driven shield around the electrode in a capacitive proximity sensor.

Currently, the capacitive bridge became increasingly popular in the design of displacement sensors. A linear bridge capacitive position sensor is shown in Fig. 6.8a. The sensor comprises two planar electrode sets that are parallel and adjacent to each other with a constant separation distance d . The increase the capacitance, the spacing between the plate sets is relatively small. A stationary electrode set contains four rectangular elements, whereas a moving electrode set contains two rectangular elements. All six elements are of about the

same size (a side dimension is b). The size of each plate can be as large as is mechanically practical when a large range of linearity is desired. The four electrodes of the stationary set are cross-connected electrically, thus forming a bridge-type capacitance network. A bridge excitation source provides a sinusoidal voltage (5–50 kHz) and the voltage difference between the pair of moving plates is sensed by the differential amplifier whose output is connected to the input of a synchronous detector. The capacitance of two parallel plates, of fixed separation distance, is proportional to the area of either plate which directly faces the corresponding area of the other plate. Figure 6.8b shows the equivalent circuit of the sensor which has a configuration of a capacitive bridge. A mutual shift of the plates with respect to a fully symmetrical position results in the bridge disbalance and the phase-sensitive output of the differential amplifier. An advantage of the capacitive bridge circuit is the same as of any bridge circuit: linearity and noise immunity. In addition to the flat electrodes as described earlier, the same method can be applied any symmetrical arrangement of the sensor, (e.g., to detect a rotary motion).

(d) Inductive and Magnetic Sensors

One of many advantages of using magnetic field for sensing position and distance is that any nonmagnetic material can be penetrated by the field with no loss of position accuracy. Stainless steel, aluminum, brass, copper, plastics, masonry, and woods can be penetrated, meaning that the accurate position with respect to the probe at the opposite side of a wall can be determined almost instantly. Another advantage is the magnetic sensors can work in severe environments and corrosive situations because the probes and targets can be coated with inert materials that will not adversely affect the magnetic fields.

1. LVDT and RVDT

Position and displacement may be sensed by methods of electromagnetic induction. A magnetic flux coupling between two coils may be altered by the movement of an object and subsequently converted into voltage. Variable-inductance sensors that use a nonmagnetized ferromagnetic medium to alter the reluctance (magnetic resistance) of the flux path are known as variable reluctance transducers. The basic arrangement of a multi-induction transducer contains two coils: primary and secondary. The primary carries ac excitation (V_{ref}) that induces a steady ac voltage in the secondary coil (Fig. 6.9). The induced amplitude depends on flux coupling between the coils. There are two techniques for changing the coupling. One is the movement of an object made of ferromagnetic material within the flux path. This changes the reluctance of the path, which, in turn, alters the coupling between the coils. This is the basis for the operation of a LVDT (linear variable differential transformer), a RVDT (rotary variable differential transformer), and the mutual inductance proximity sensors. The other method is to physically move one coil with respect to another. The LVDT is a transformer with a mechanically actuated core. The primary coil is driven by a sine wave (excitation signal) having a stabilized amplitude. The sine wave eliminates error-related harmonics in the transformer. An ac signal is induced in the secondary coils. A core made of a ferromagnetic material is inserted coaxially into the cylindrical opening without physically touching the coils. The two secondaries are connected in the opposed phase. When the core is positioned in the magnetic center of the transformer, the secondary output signals cancel and there is no output voltage. Moving the core away from the central position unbalances the induced magnetic flux ratio between the

secondaries, developing an output. As the core moves, the reluctance of the flux path changes. Hence, the degree of flux coupling depends on the axial position of the core. At a steady state, the amplitude of the induced voltage is proportional, in the linear operating region, to the core displacement. Consequently, voltage may be used as a measure of a displacement.

The LVDT provides the direction as well as magnitude of the displacement. The direction is determined by the phase angle between the primary (reference) voltage and the secondary voltage. Excitation voltage is generated by a stable oscillator. To exemplify how the sensor works, Fig.6.10 shows the LVDT connected to a synchronous detector which rectifies the sine wave and presents it at the output as a dc signal. The synchronous detector is composed of an analog multiplexer (MUX) and a zero-crossing detector which converts the sine wave into the square pulses compatible with the control input of the multiplexer. A phase of the zero-crossing detector should be trimmed for the zero output at the central position of the core. The output amplifier can be trimmed to a desirable gain to make the signal compatible with the next stages. The synchronized clock to the multiplexer means that the information presented to the RC filter at the input of the amplifier is amplitude and phase sensitive. The output voltage represents how far the core is from the center and on which side.

For the LVDT to measure transient motions accurately, the frequency of the oscillator must be at least 10 times higher than the highest significant frequency of the movement. For the slow-changing process, stable oscillator may be replaced by coupling to a power line frequency of 60 or 50 Hz. Advantages of the LVDT and RVDT are the following: (1) The sensor is a noncontact device with no or very little friction resistance with small resistive forces; (2) hystereses (magnetic and mechanical) are negligible; (3) output impedance is very low; (4) there is low susceptibility to noise and interferences; (5) its construction is solid and robust, (6) infinitesimal resolution is possible. One useful application for the LVDT sensor is in the so-called *gauge heads*, which are used in tool inspection and gauging equipment. In that case, the inner core of the LVDT is spring loaded to return the measuring head to a preset reference position. The RVDT operates on the same principle as LVDT, except that a rotary ferromagnetic core is used. The prime use for the RVDT is the measurement of angular displacement. The linear range of measurement is about $\pm 40^\circ$, with a nonlinearity error of about 1%.

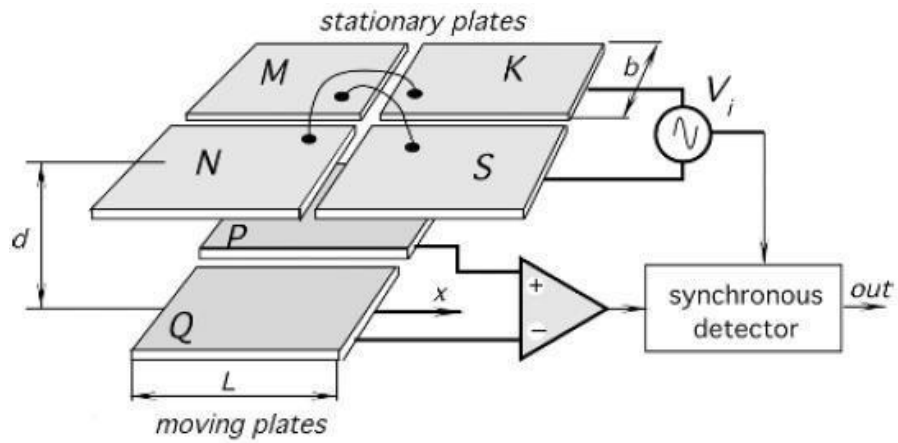

(A)

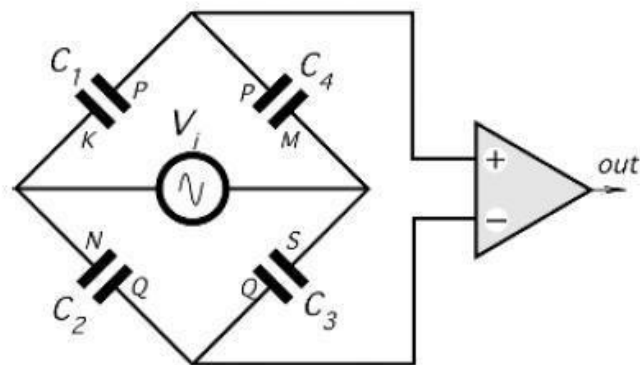

(B)

Figure (6.8): Parallel-plate capacitive bridge sensor: (A) plate arrangement, (B) equivalent circuit diagram.

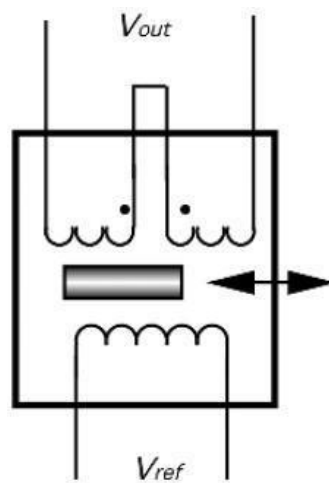

Figure (6.9): Circuit diagram of the LVDT sensor.

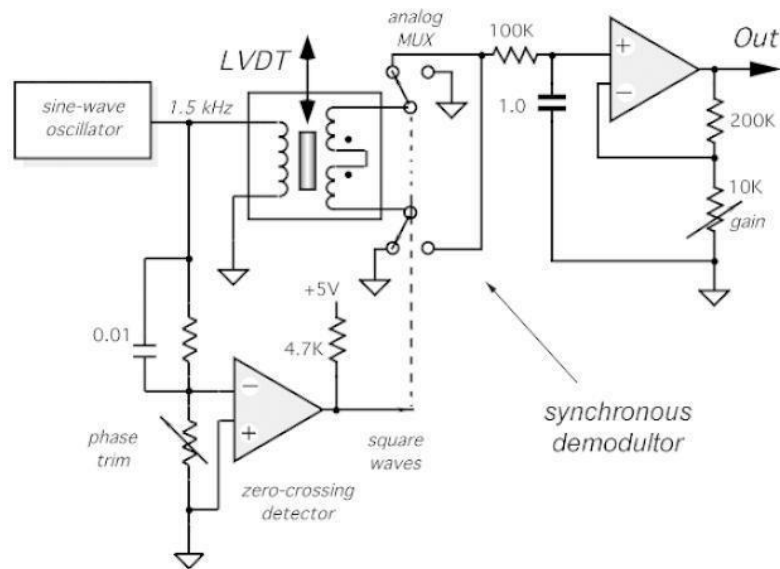

Figure (6.10): A simplified circuit diagram of an interface for an LVDT sensor.

2. Eddy Current Sensors

To sense the proximity of nonmagnetic but conductive materials, the effect of *eddy currents* is used in a dual-coil sensor (Fig. 6.11a). One coil is used as a reference, and the other is for the sensing of the magnetic currents induced in the conductive object. Eddy (circular) currents produce a magnetic field which opposes that of the sensing coil, thus resulting in a disbalance with respect to the reference coil. The closer the object to the coil, the larger the change in the magnetic impedance. The depth of the object where eddy currents are produced is defined by

$$\delta = \frac{1}{\sqrt{\pi f \mu \sigma}}$$

Where f is the frequency and σ is the target conductivity. Naturally, for effective operation, the object thickness should be larger than the depth. Hence, eddy detectors should not be used for detecting metallized film or foil objects. Generally, the relationship between the coil impedance and distance to the object x is nonlinear and temperature dependent. The operating frequency of the eddy current sensors range from 50 kHz to 10 MHz. Figures 6.11b and 6.11c show two configurations of the eddy sensors: with the shield and without one. The shielded sensor has a metal guard around the ferrite core and the coil assembly. It focuses the electromagnetic field to the front of the sensor. This allows the sensor to be imbedded into a metal structure without influencing the detection range. The unshielded sensor can sense at its sides as well as from the front. As a result, the detecting range of an unshielded sensor is usually somewhat greater than that of the shielded sensor of the same diameter. To operate properly, the unshielded sensors require nonmetallic surrounding objects. In addition to position detection, eddy sensors can be used to determine material thickness, nonconductive coating thickness, conductivity and plating measurements, and cracks in the material. Crack detection and surface flaws become the most popular applications for the sensors. Depending on the applications, eddy probes may be of many coil configurations: Some are very small in diameter (2–3 mm) and others are quite large (25 mm). Some companies even make custom-designed probes to meet unique requirements of the customers (Staveley Instruments, Inc., Kennewick, WA). One important advantage of the eddy current sensors is that they do not need magnetic material for the operation, thus they can be quite effective at high temperatures (well exceeding the Curie temperature of a

magnetic material) and for measuring the distance to or level of conductive liquids, including molten metals. Another advantage of the detectors is that they are not mechanically coupled to the object and, thus, the loading effect is very low.

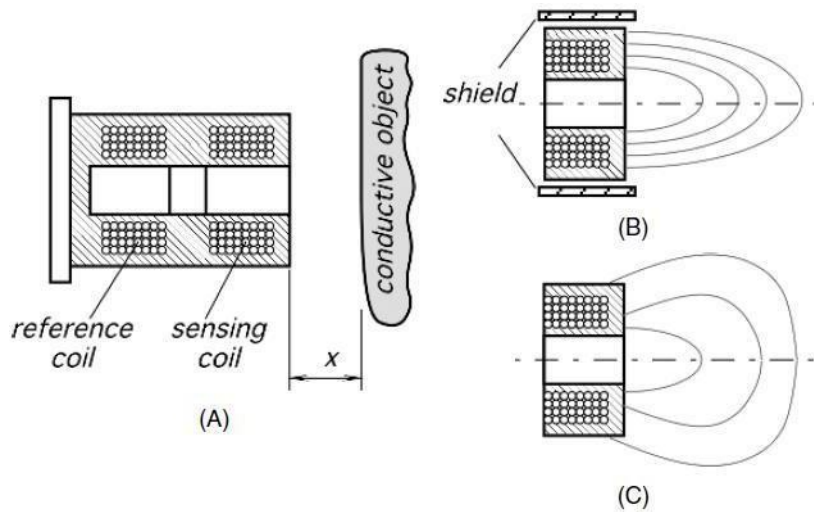

Figure (6.11): (A) Electromagnetic proximity sensor; (B) sensor with the shielded front end; (C) unshielded sensor.

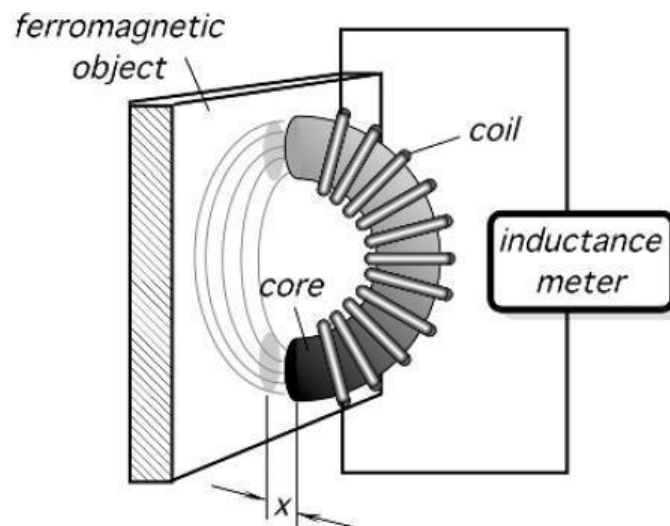

Figure (6.12): A transverse inductive proximity sensor.

3. Transverse Inductive Sensor

Another position-sensing device is called a *transverse inductive proximity sensor*. It is useful for sensing relatively small displacements of ferromagnetic materials. As the name implies, the sensor measures the distance to an object which alters the magnetic field in the coil. The coil inductance is measured by an external electronic circuit (Fig. 6.12). A self-induction principle is the foundation for the operation of such a transducer. When the proximity sensor moves into the vicinity of a ferromagnetic, object, its magnetic field changes, thus altering the inductance of the coil. The advantage of the sensor is that it is a noncontact device whose interaction with the object is only through the magnetic field. An obvious limitation is that it is useful only for the ferromagnetic objects at relatively short distances.

A modified version of the transverse transducer is shown in Fig. 6.13a. To overcome the limitation for measuring only ferrous materials, a ferromagnetic disk is attached to a displacing object while the coil is in a stationary position. Alternatively, the coil may be attached to the object and the core is stationary. This proximity sensor is useful for

measuring small displacements only, as its linearity is poor in comparison with the LVDT. However, it is quite useful as a proximity detector for the indication of the close proximity to an object which is made of any solid material. The magnitude of the output signal as function of distance to the disk is shown in Fig. 6.13b.

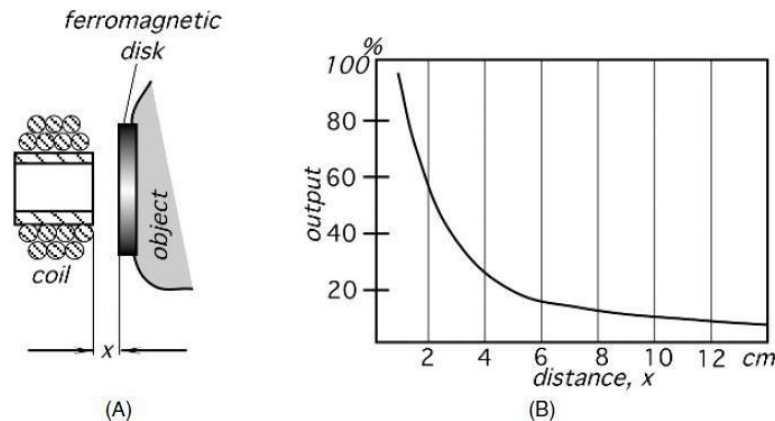

Figure (6.13): Transverse sensor with an auxiliary ferromagnetic disk (A) and the output signal as function of distance (B).

4. Hall Effect sensors

Hall Effect—Position Sensor

The Hall Effect is shown in *Figure 6-14a*. E.H. Hall discovered it. If there is current in a conductor and a magnetic field is applied perpendicular to the direction of the current, a voltage will be generated in the conductor that has a direction perpendicular to both the direction of the current and the direction of the magnetic field. This property is very useful in making sensors, especially when a semiconductor chip is used for the conductor. Not only can the semiconductor be used to generate the Hall voltage, but additional circuitry can be built into the semiconductor to process the Hall voltage. As a result, not only are there linear sensors that generate an output voltage that is proportional to the magnitude of the magnetic flux applied, but, because circuitry can be added to the chip, there are sensors that have switched logic-level outputs, or latched outputs, or outputs whose level depends on the difference between two applied magnetic fields.

Hall Effect—Switch

Figure 6-14b shows a Hall-effect switch and its output when used as a sensor. When the magnetic flux exceeds β_{ON} in maxwells, the output transistor of the switch is ON, and when the field is less than β_{OFF} , the output transistor is OFF. There is a hysteresis curve as shown. When the output transistor is OFF, the magnetic field must be greater than zero by β_{ON} before the transistor is ON, but will stay ON until the magnetic field is less than zero by β_{OFF} . The zero magnetic field point can be $-biased$ up to a particular value by applying a steady field to make $\beta_0 = \beta_{STEADY-STATE}$.

Hall Effect—Linear Position

A linear Hall-effect sensor is shown in *Figure 6-14c*. Its output voltage varies linearly as the magnetic field varies. When the field is zero, there is a quiescent voltage = V_{OQ} . If the field is $+\beta$ (north to south), the voltage V_o increases from V_{OQ} ; if the field is β (south to north),

the voltage V_o decreases from V_{OQ} . The supply voltage is typically 3.8V to 24V for Hall-effect devices.

Hall Effect—Brake Pedal Position

A brake pedal position sensor is shown in *Figure 6-15a*. A Hall-effect switching sensor is used. Stepping on the brake moves a magnet away from the Hall-effect sensor and its output switches to a low voltage level turning on the brake light. When the brake is released, the magnetic field is again strong enough to switch the output V_o to a high level, turning off the brake light.

Hall Effect—Linear Position Sensor

In *Figure 6-15b*, as the magnet is moved over the sensor the magnetic field produces an output V_o that is proportional to the strength of the field. The linear output voltage can be converted to a meter reading that indicates the linear position of the assembly that moves the magnet. Amplifying V_o can increase the sensitivity of the measurement.

Hall Effect—Angular Position Sensor

A round magnet, half North Pole and half South pole, is rotated in front of a linear Hall-effect sensor as shown in *Figure 6-15c*. As the magnet turns the magnetic field varies and produces an output V_o that is proportional to the angular rotation. V_o can be converted to a meter reading calibrated in degrees of rotation.

Hall Effect—Current Sensor

Current in a wire produces a magnetic field around the wire as shown in *Figure 6-15d*. If the wire is passed through a soft-iron yoke, the soft iron collects the magnetic field and directs it to a linear Hall-effect sensor. The magnetic field varies as the amplitude of the current varies, which produces a corresponding proportional V_o from the linear sensor, and, thus, a sensor that detects the amplitude of the current. An alternating current is shown in *Figure 6-15d*; therefore, the voltage V_o will be an alternating voltage. V_o is detected in *Figure 6-15d* using an oscilloscope.

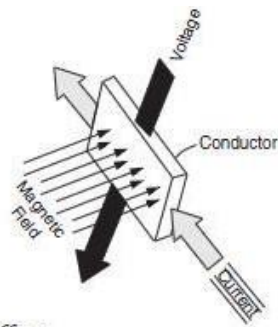

The Hall Effect:
 If a conductor has a current in it, and a magnetic field is applied perpendicular to the direction of the current, a voltage (the Hall voltage) is generated in a direction perpendicular to both the current and the magnetic field.

a. Hall effect

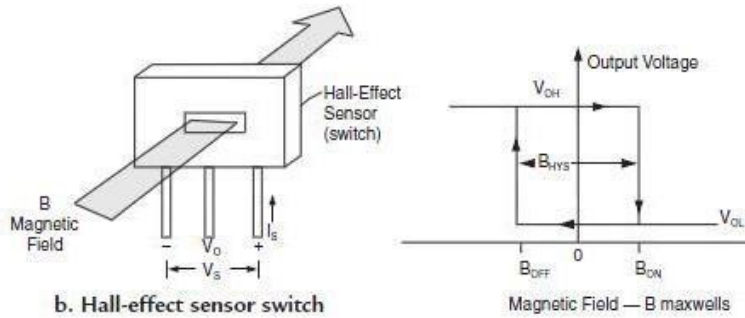

b. Hall-effect sensor switch

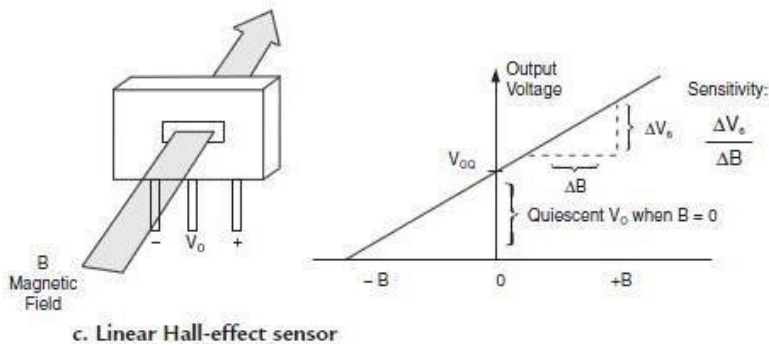

c. Linear Hall-effect sensor

Figure (6.14): Hall Effect sensors

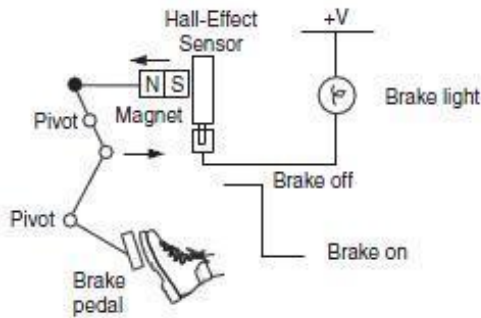

a. Hall-effect position sensor (switch)

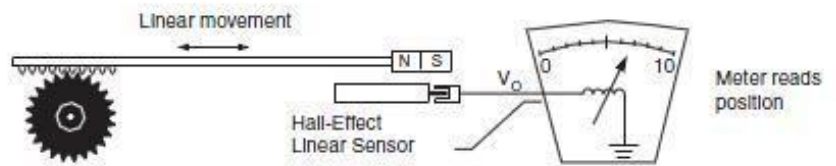

b. Linear position sensor

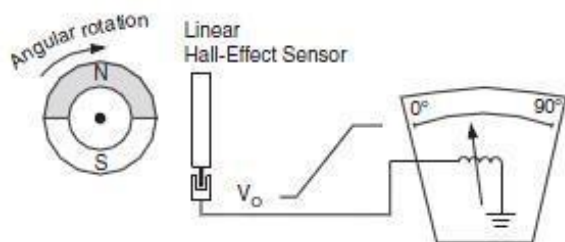

c. Angular position sensor

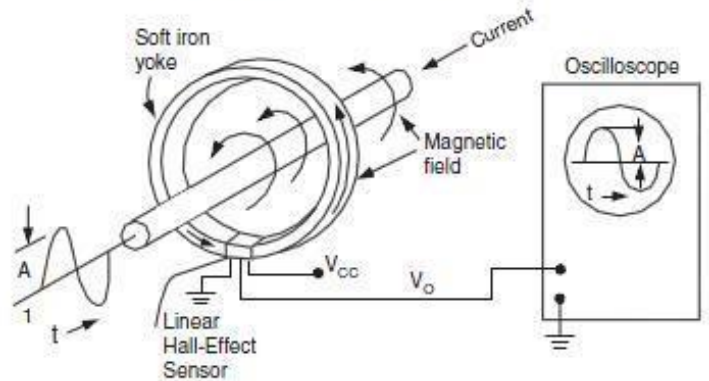

d. Current sensor

Figure (6.15): Hall Effect sensor applications

(e) Optical Sensors

After mechanical contact and potentiometric sensors, optical sensors are probably the most popular for measuring position and displacement. Their main advantages are simplicity, the absence of the loading effect, and relatively long operating distances. They are insensitive to stray magnetic fields and electrostatic interferences, which makes them quite suitable for many sensitive applications. An optical position sensor usually requires at least three essential components: a light source, a photodetector, and light guidance devices, which may include lenses, mirrors, optical fibers, and so forth. Similar arrangements are often implemented without optical fibers when light is guided toward a target by focusing lenses and is diverted back to detectors by the reflectors. Currently, this basic technology has been substantially improved. Some more complex and sophisticated products have evolved. The improvements are aimed to better selectivity, noise immunity, and reliability of the optical sensors.

1. Optical Bridge

The concept of a bridge circuit, like a classical Wheatstone bridge, is employed in many sensors and the optical sensor is a good example of that. One such use shown in Fig. 6.16. A four-quadrant photodetector consists of four light detectors connected in a bridge like circuit. The object must have an optical contrast against the background. Consider a positioning system of a spacecraft (Fig. 6.16a). An image of the Sun or any other sufficiently bright object is focused by an optical system (a telescope) on a four-quadrant photodetector. The opposite parts of the detector are connected to the corresponding inputs of the difference amplifiers (Fig. 6.16b). Each amplifier produces the output signal proportional to a displacement of the image from the optical center of the sensor along a corresponding axis. When the image is perfectly centered, both amplifiers produce zero outputs. This may happen only when the optical axis of the telescope passes through the object.

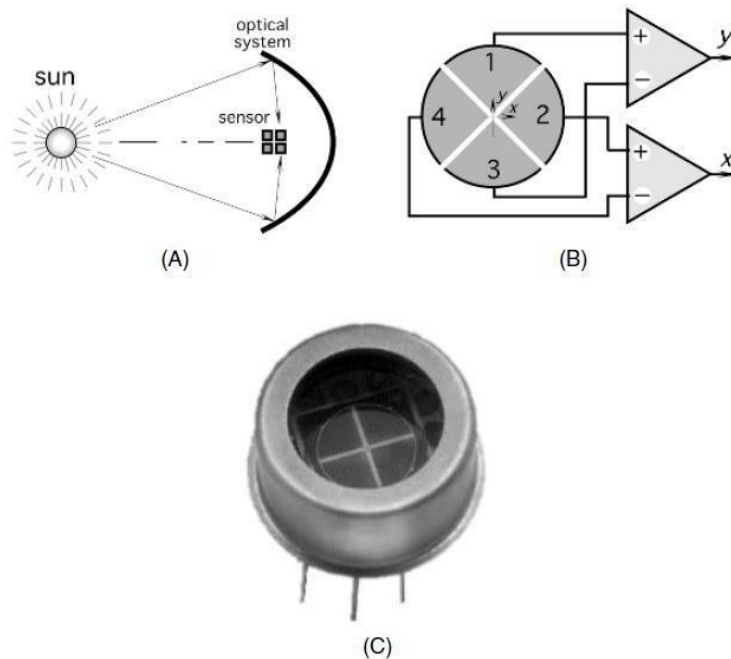

Figure (6.16): Four-quadrant photodetector: (A) focusing an object on the sensor; (B) connection of the sensing elements to difference amplifiers; (C) sensor in a packaging. (From Advanced Photonix, Inc. Camarillo, CA.)

2. Proximity Detector with Polarized Light

One method of building a better optoelectronic sensor is to use polarized light. Each light photon has specific magnetic and electric field directions perpendicular to each other and to the direction of propagation. The direction of the electric field is the direction of the light *polarization*. Most of the light sources produce light with randomly polarized photons. To make light polarized, it can be directed through a polarizing filter, (i.e., a special material which transmits light polarized only in one direction and absorbs and reflects photons with wrong polarizations).

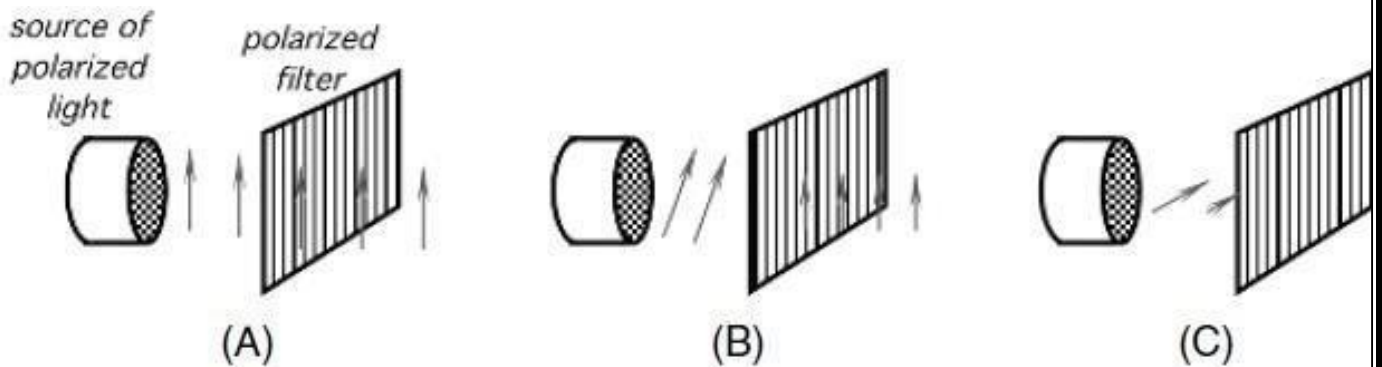

Figure (6.17): Passing polarized light through a polarizing filter: (A) direction of polarization is the same as of the filter; (B) direction of polarization is rotated with respect to the filter; (C) direction of polarization is perpendicular with respect to the filter.

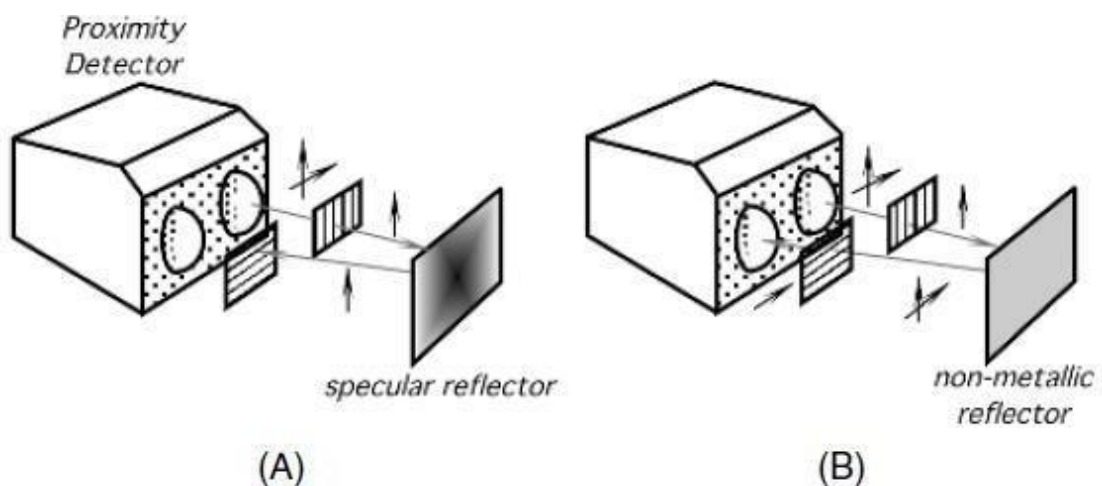

Figure (6.18): Proximity detector with two polarizing filters positioned at a 90° angle with respect to one another: (A) polarized light returns from the metallic object within the same plane of polarization; (B) nonmetallic object depolarizes light, thus allowing it to pass through the polarizing filter.

However, any direction of polarization can be represented as a geometrical sum of two orthogonal polarizations: One is the same as the filter and the other is nonpassing. Thus, by rotating the polarization of light before the polarizing filter, we may *gradually* change the

light intensity at the filter's output (Fig. 6.17). When polarized light strikes an object, the reflected light may retain its polarization (specular reflection) or the polarization angle may change. The latter is typical for many nonmetallic objects. Thus, to make a sensor nonsensitive to reflective objects (like metal cans, foil wrappers, and the like), it may include two perpendicularly positioned polarizing filters: one at the light source and the other at the detector (Figs. 6.18a and 6.18b). The first filter is positioned at the emitting lens (light source) to polarize the outgoing light. The second filter is at the receiving lens (detector) to allow passage of only those components of light which have a 90 degree rotation with respect to the outgoing polarization. Whenever light is reflected from a specular reflector, its polarization direction does not change and the receiving filter will not allow the light to pass to a photodetector. However, when light is reflected in a nonspecular manner, its components will contain a sufficient amount of polarization to go through the receiving filter and activate the detector. Therefore, the use of polarizers reduces false-positive detections of nonmetallic objects.

(f) Ultrasonic Sensors

For noncontact distance measurements, an active sensor which transmits some kind of a pilot signal and receives a reflected signal can be designed. The transmitted energy may be in the form of any radiation—for instance, electromagnetic in the optical range electromagnetic in the microwave range, acoustic, and so forth. Transmission and reception of the ultrasonic energy is a basis for very popular ultrasonic-range meters, and velocity detectors. Ultrasonic waves are mechanical acoustic waves covering the frequency range well beyond the capabilities of human ears (i.e., over 20 kHz). However, these frequencies may be quite perceptible by smaller animals, like dogs, cats, rodents, and insects. Indeed, the ultrasonic detectors are the biological ranging devices for bats and dolphins. When the waves are incident on an object, part of their energy is reflected. In many practical cases, the ultrasonic energy is reflected in a diffuse manner; that is, regardless of the direction from which the energy comes, it is reflected almost uniformly within a wide solid angle, which may approach 180 degree. If an object moves, the frequency of the reflected waves will differ from the transmitted waves. This is called the Doppler Effect. The distance L_o to the object can be calculated through the speed v of the ultrasonic waves in the media, and the angle, (Fig. 6.19a):

$$L_o = \frac{v t \cos\theta}{2}$$

Where t is the time for the ultrasonic waves to travel to the object and back to the receiver. If a transmitter and a receiver are positioned close to each other as compared with the distance to the object, then $\cos\theta = 1$. Ultrasonic waves have an obvious advantage over the microwaves: they propagate with the speed of sound, which is much slower than the speed of light at which microwaves propagate. Thus, the time t is much longer and its measurement can be accomplished easier and less expensively.

To generate any mechanical waves, including ultrasonic, the movement of a surface is required. This movement creates compression and expansion of a medium, which can be gas (air), liquids, or solids. The most common type of excitation device which can generate surface movement in the ultrasonic range is a piezoelectric transducer operating in the so-called *motor* mode. The name implies that the piezoelectric device directly converts electrical energy into mechanical energy.

Figure 6.20a shows that the input voltage applied to the ceramic element causes it to flex and transmit ultrasonic waves. Because piezoelectricity is a reversible phenomenon, the ceramic generates voltage when incoming ultrasonic waves flex it. In other words, the element may work as both the transmitter and the receiver (a microphone). A typical operating frequency of the transmitting piezoelectric element is near 32 kHz. For better efficiency, the frequency of the driving oscillator should

be adjusted to the resonant frequency f_r of the piezoelectric ceramic (Fig. 6.19b), where the sensitivity and efficiency of the element is best. When the measurement circuit operates in a pulsed mode, the same piezoelectric element is used for both transmission and receiving.

When the system requires the continuous transmission of ultrasonic waves, separate piezoelectric elements are employed for the transmitter and receiver. A typical design of an air-operating sensor is shown in Figs. 6.20b and 6.21a. A directional sensitivity diagram (Fig.6.21b) is important for a particular application. The narrower the diagram, the more sensitive the transducer is.

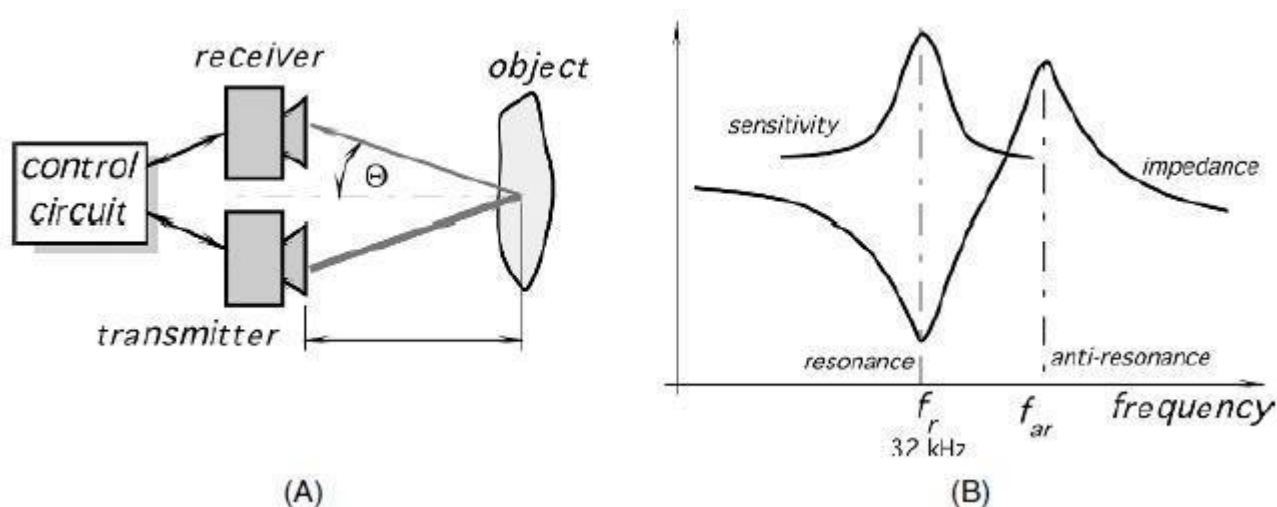

Figure (6.19): Ultrasonic distance measurement: (A) basic arrangement; (B) impedance characteristic of a piezoelectric transducer.

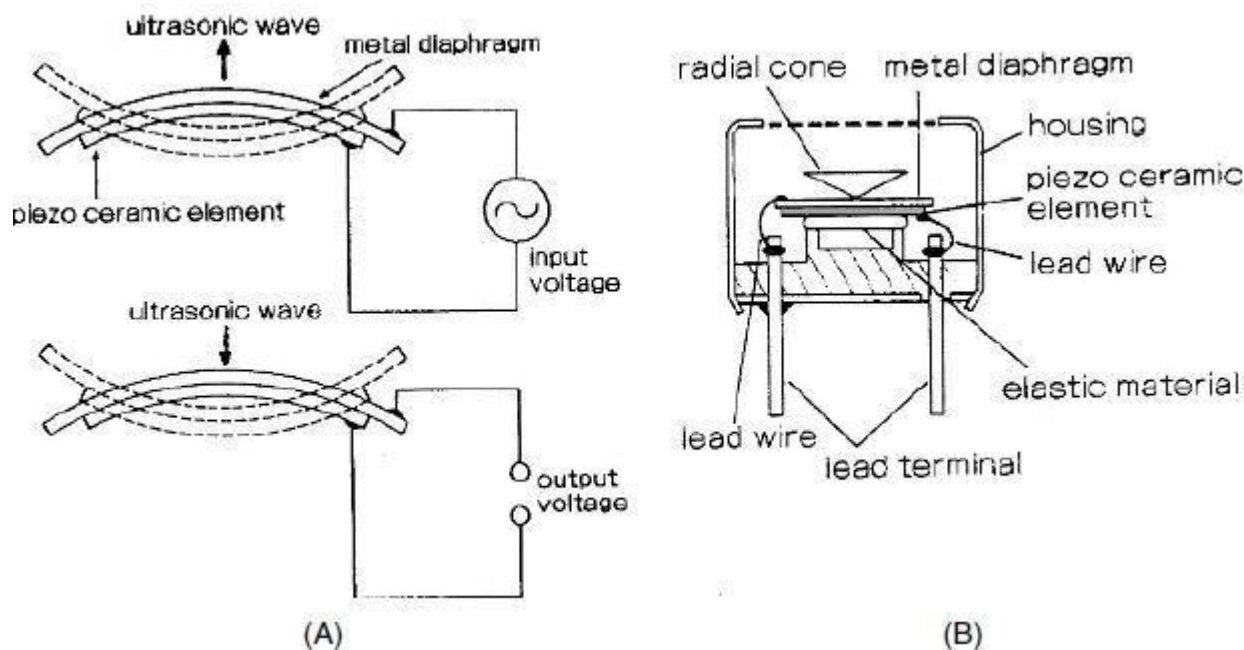

Figure (6.20): Piezoelectric ultrasonic transducer: (A) input voltage flexes the element and transmits ultrasonic waves, whereas incoming waves produce output

voltage; (B) open-aperture type of ultrasonic transducer for operation in air.
(Courtesy of Nippon Ceramic, Japan.)

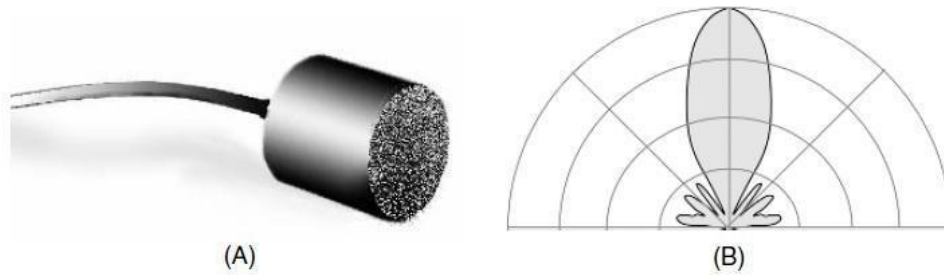

Figure (6.21): (A) ultrasonic transducer for air. (B) directional diagram.

(g) Radar Sensors

Micropower Impulse Radar

In 1993, Lawrence Livermore National Laboratory had developed a *micropower impulse radar* (MIR), which is a low-cost noncontact ranging sensor. The operating principle of the MIR is fundamentally the same as that of a conventional pulse radar system, but with several significant differences. The MIR (Fig. 6.22) consists of a white-noise generator whose output signal triggers a pulse generator. The pulse generator produces very short pulses with an

average rate of $2\text{MHz} \pm 20\%$. Each pulse has a fixed short duration τ , whereas the repetition of these pulses is random, according to triggering by the noise generator. The pulses are spaced randomly with respect to one another in a Gaussian-noise like pattern. The distance between pulses range from 200 to 625 ns.

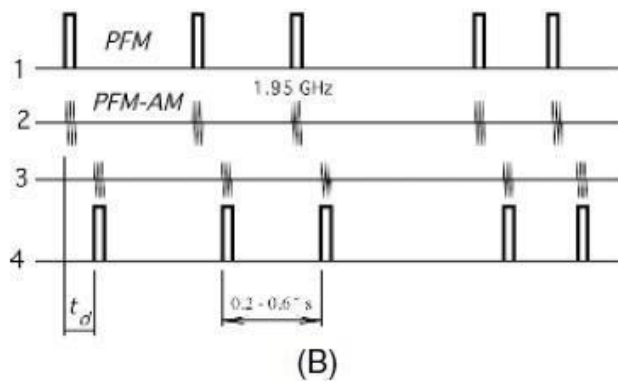
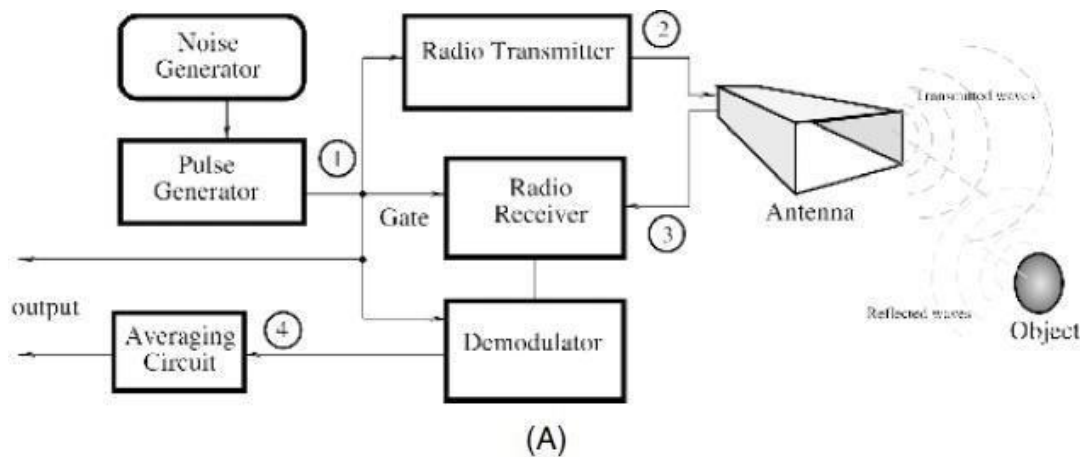

Figure (6.22): Block diagram of micropower radar (A) and the timing diagram (B).

It can be said that the pulses have a pulse-frequency modulation (PFM) by white noise with maximum index of 20%. In turn, the square-wave pulses cause the amplitude modulation (AM) of a radio transmitter. The modulation has a 100% depth; that is, the transmitter is turned on and off by the pulses. Such a double-step modulation is called PFM-AM. The radio transmitter produces short bursts of high-frequency radio signal which propagate from the transmitting antenna to the surrounding space. The electromagnetic waves reflect from the objects and propagate back to the radar. The same pulse generator which modulates the transmitter gates (with a predetermined delay) the radio receiver to enable the reception of the MIR only during a specific time window. Another reason for gating the receiver is to reduce its power consumption. The reflected pulses are received and demodulated (the square-wave shape is restored from the radio signal), and the time delay with respect to the transmitted pulses is measured. The time delay is proportional to the distance D from the antenna to the object from which the radio waves are reflected:

$$t = 2DC^{-1}$$

Where c is the speed of light. The carrier frequency (center frequency) of the radio transmitter is either 1.95 or 6.5 GHz. Due to very short modulating pulses, the approximate bandwidth of the radiated signal is very wide—about 500 MHz (for a 1.95-GHz carrier). The spatial distribution of the transmitted energy is determined by the type of antenna. For a dipole antenna, it covers nearly 360° , but it may be shaped to the desired pattern by employing a horn, a reflector, or a lens. Because of the unpredictable modulation pattern, the wide bandwidth, and a low spectral density of the transmitted signal, the MIR system is quite immune to countermeasures and virtually is stealthy—the radiated energy is perceived by any nonsynchronous receiver as white thermal noise. The average duty cycle of the transmitted pulses is small ($< 1\%$). Because the pulses are spaced randomly, practically any number of identical MIR systems may operate in the same space without a frequency division (i.e., they work at the same carrier frequency within the same bandwidth). There is a little chance that bursts from the interfering transmitters overlap, and if they do, the interference level is significantly reduced by the averaging circuit. Nearly 10,000 received pulses are averaged before the time delay is measured. Other advantages of the MIR are low cost and extremely low power consumption of the radio receiver, about $12\ \mu\text{W}$. The total power consumption of the entire MIR system is near $50\ \mu\text{W}$. Two AAalkaline batteries may power it continuously for several years. Applications for the MIR include range meters (Fig. 7.43), intrusion alarms, level detectors, vehicle ranging devices, automation systems, robotics, medical instruments, weapons, novelty products, and even toys where a relatively short range of detection is required.



(A)

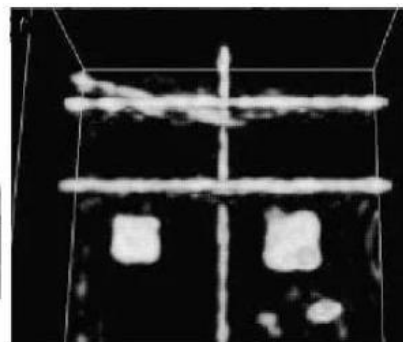

(B)

Figure (6.23): Imaging steel in concrete with MIR: (A) the internal elements of a concrete slab before pouring; (B) reconstructed 3-D MIR image of the elements embedded in the finished 30-cm-thick concrete slab.

(h) Thickness and Level Sensors

In many industrial applications, the measurement of thickness of a material is essential for manufacturing, process and quality control, safety, airspace, and so forth. The methods of thickness gauging range from the optical, to ultrasonic, to x-ray. Here, we briefly review some less known methods.

1. Ablation Sensors

Ablation is dissipation of heat by melting and removal of the sacrificial protective layer during atmospheric reentry. Aerospace vehicles subjected to significant aerodynamic heating often rely on ablating thermal protection systems (TPSs) to keep the internal structure and equipment below critical operating temperatures. An ablating TPS undergoes chemical decomposition or phase change (or both) below the internal structure's critical temperature. Incident thermal energy is then channeled into melting, subliming, or decomposing the ablator. The ablator recession rate is directly proportional to the flux at the surface. A measure of ablator thickness is required to estimate surface heat flux. Thus, an ablation sensor is a kind of position sensor that detects position of the ablation layer's outer surface and provides a measure of the remaining thickness. The ablation sensors can be built into the ablation layer (intrusive sensors) or be noninvasive.

The intrusive sensors include the breakwire ablation gauge, radiation transducer (RAT) sensor, and light pipe. The breakwire ablation gauge consists of several thin wires implanted at various known levels in an ablator. As the material progressively erodes, each successive wire is broken and results in an open circuit. Figure 6.24a illustrates this concept. In some cases breakwire doubles as a thermocouple (TC) and each is situated so that no breakwire TC is directly above another. This arrangement allows an unobstructed conduction path through the ablator to each breakwire TC, including those at lower levels. Although the breakwire method provides temperature time histories until the last TC is exposed and destroyed, this method only provides recession data at a few distinct points. The light pipe sensor consists of quartz fibers implanted in an ablator and terminated at known depths (Fig. 6.24b). When the TPS recedes to where a fiber terminates, light transmits down to a photodiode. This method provides recession data at distinct points only and does not provide temperature data, as the breakwire method does.

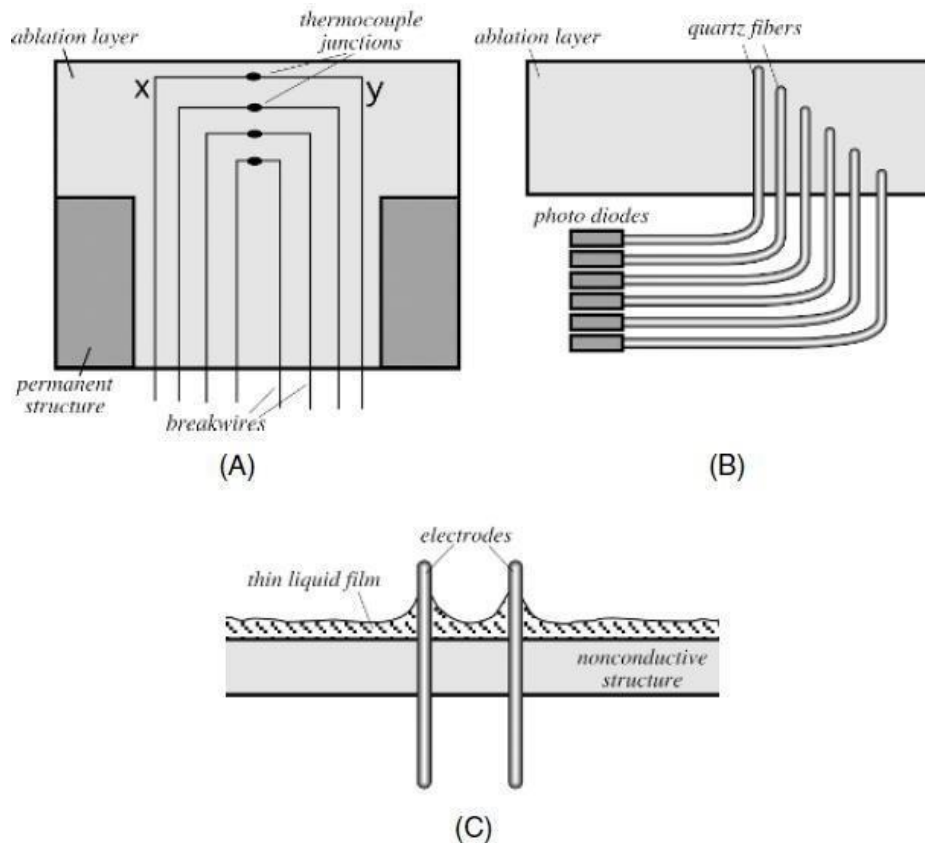

Figure (6.24): Breakwire concept with thermocouples consisting of metals x and y (A); light pipe concept (B); and measurement of thin-film liquid by a capacitive method (C).

Entirely noninvasive sensor for measuring the ablation layer can be built by using the capacitive method. The sensor is made in the form of two electrodes that may have a variety of shapes. The sensor is placed in series with an inductor and a resistor forming an resistive, inductive, and capacitive (RLC) termination to a waveguide (i.e., a coaxial cable). The arrangement shown in Fig. 6.25 is very similar to a transmitter–antenna configuration. The RLC termination has a resonant frequency approximated by

$$F_0 = \frac{1}{2\pi\sqrt{LC}}$$

When electromagnetic energy at the resonant frequency is sent down the waveguide, all of the energy dissipates in the resistor. If, however, the resonant frequency of the termination changes (say, because of a change in capacitance), a fraction of the energy is reflected back toward the source. As the capacitance continues to change, the energy reflected increases. Antennas that work like this are said to be out of tune. In this situation, one could use a commercially available reflection-coefficient bridge (RCB) between the radio-frequency (RF) source and the waveguide termination. The RCB generates a dc voltage proportional to the energy reflected. Then, the antenna can be when electromagnetic energy at the resonant frequency is sent down the waveguide, all of the energy dissipates in the resistor. If, however, the resonant frequency of the termination changes (say, because of a change in capacitance), a fraction of the energy is reflected back toward the source. As the capacitance continues to change, the energy reflected increases. Antennas that work like this are said to be out of tune. In this situation, one could use a commercially available reflection-coefficient bridge (RCB) between the radio-frequency (RF) source and the waveguide termination. The RCB generates a dc voltage proportional to the energy reflected. Then, the

antenna can be adjusted until the bridge output voltage is a minimum and the energy transmitted is a maximum.

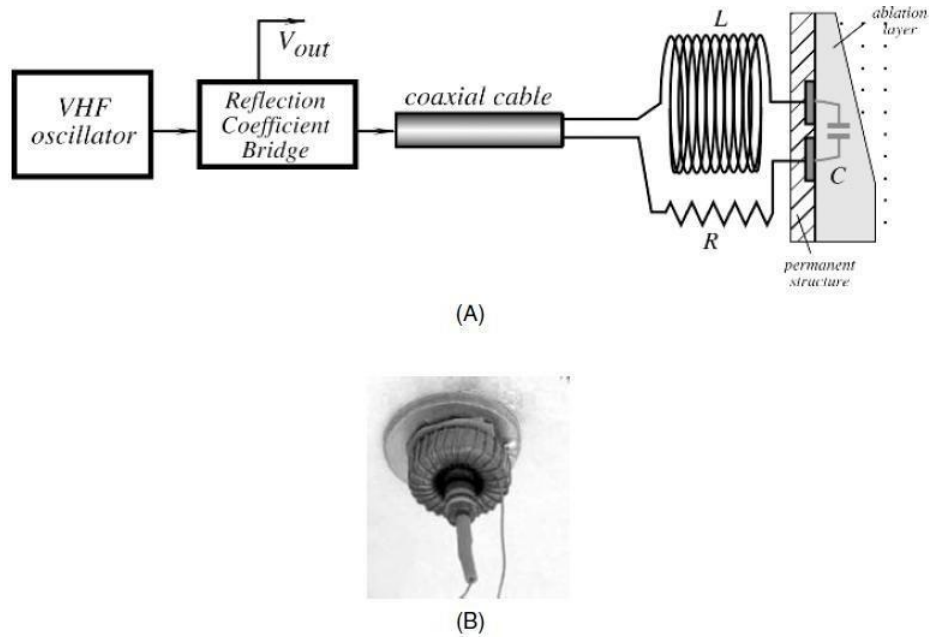

Figure (6.25): Block diagram of resonant ablation gauge (A) and prototype sensor (B).

2. Liquid-Level Sensors

There are many ways to detect levels of liquids. They include the use of the resistive, optical, magnetic, and capacitive sensors. The choice of a particular sensor depends on many factors, but probably the defining factor is the type of a liquid. One of the most challenging is liquid gases, especially liquid helium, which has a low density and low dielectric constant, not mentioning its storage in the enclosed Dewar bottles at a cryogenic temperature. In such difficult cases, a transmission-line sensor may be quite efficient. The sensor operates on a principle that is similar to the one that was described for ablation sensing (Fig. 6.25). For detecting the liquid levels, the transmission-line sensor may be constructed as shown in Fig. 6.26. The probe resembles a capacitive-level sensor. The probe resembles a capacitive-level sensor, the probe looks like a long tube with an inner electrode surrounded by the outer cylindrical electrode. The probe is immersed into liquid, which may freely fill the space between the electrodes. The electrodes are fed with a high-frequency signal (about 10 MHz). The length of the probe can be any practical wavelength but for a linear response, it is advisable to keep it less than $(1/4)\lambda$. The high-frequency signal propagates along the transmission line that is formed by the two electrodes.

The liquid fills the space between the electrodes up to a particular level x . Because the dielectric constant of a liquid is different from its vapor, the properties of the transmission line depend on the position of the borderline between liquid and vapor (in other words, on the liquid level). The high-frequency signal is partially reflected from the liquid–vapor borderline and propagates back toward the upper portion of the sensor. To some degree, it resembles radar that sends a pilot signal and receives the reflection. By measuring a phase shift between the transmitted and reflected signals, the position of the borderline can be computed. The phase-shift measurement is resolved by a phase comparator that produces a dc voltage at its output. A higher dielectric constant produces a better reflection and, thus, the sensitivity of the sensor improves accordingly (Fig. 6.26b).

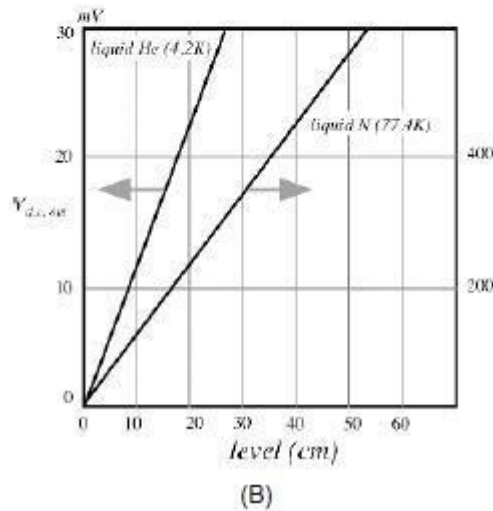
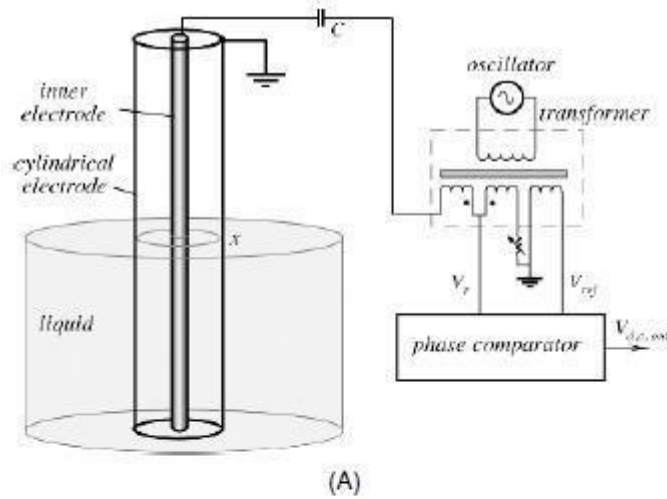

Figure (6.26): Transmission-line probe (A) and transfer functions (B).

(I) Position Sensor Practical Application —Fuel Level

That example in *Fig. 6.16a* will be used to demonstrate the sensing function. The complete sensor consists of a float that rides on the surface of fuel in a fuel tank, a lever arm connected to the float at one end, and, at the other end, connected to the shaft of a potentiometer (variable resistor). As the fuel level changes, the float moves and rotates the variable contact on the potentiometer. The schematic of *Fig. 3.16b* shows that the potentiometer is connected across the automobile battery from +12V to ground. The variable contact on the potentiometer moves in a proportional manner. When the contact is at the end of the potentiometer that is connected to ground, the output voltage will be zero volts from the variable contact to ground. At the other end, the one connected to +12V, there will be +12V from the variable contact to ground. For any position of the variable contact in between the end points, the voltage from the variable contact to ground will be proportional to the amount of the shaft rotation. Calibrating it as shown in *Fig. 6-16c* completes the liquid-level sensor. At a full tank, the float, lever arm and potentiometer shaft rotation are designed so that the variable contact is at the +12V end of the potentiometer. When the tank is empty, the same combination of elements results in the variable contact at the ground level (0V). Other positions of the float result in proportional output voltages between the variable contact and ground. As *Fig.6-16c* shows, a three-quarter full tank gives an output of 9V, a half-full tank will give an output of 6V, and a one-quarter full tank will give an output of 3V. Thus, adding a voltmeter to measure the voltage from the variable contact to ground, marked in liquid level, completes the automotive fuel gauge. Sensors that convert a physical quantity into an

electrical voltage output are very common. The output voltage can be anywhere from microvolts to tens of volts.

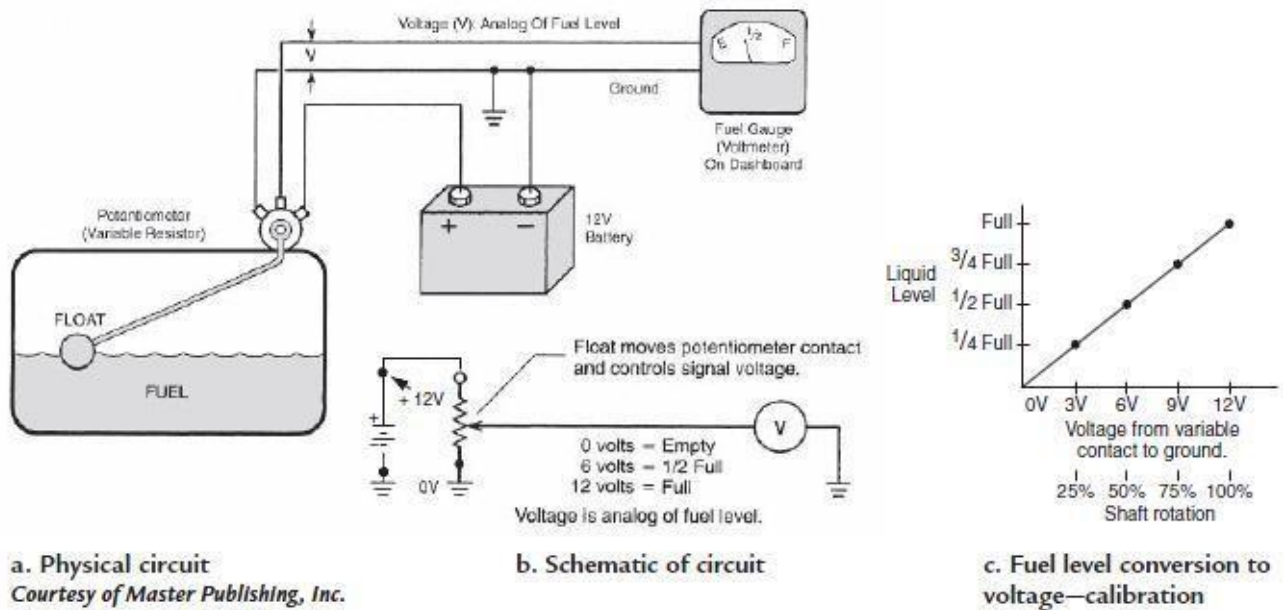

Figure (6.16): Position sensor – fuel level gauge

7. Velocity and Acceleration

Acceleration is a dynamic characteristic of an object, because, according to Newton's second law, it essentially requires application of a force. In effect, the position, velocity, and acceleration are all related: Velocity is a first derivative of position and acceleration is the second derivative. However, in a noisy environment, taking derivatives may result in extremely high errors, even if complex and sophisticated signal conditioning circuits are employed. Therefore, velocity and acceleration are not derived from the position detectors, but rather measured by special sensors. As a rule of thumb, in low-frequency applications (having a bandwidth on the order of 1 Hz), position and displacement measurements generally provide good accuracy. In the intermediate-frequency applications (less than 1 kHz), velocity measurement is usually favored. In measuring high-frequency motions with appreciable noise levels, acceleration measurement is preferred.

Velocity (speed or rate of motion) may be linear or angular; that is, it shows how fast an object moves along a straight line or how fast it rotates. The measure of velocity depends on the scale of an object and may be expressed, say, in millimeters per second or miles per hour. Currently, the speed of a large object, especially of a land or water vehicle, may be very efficiently determined by a GPS (Geo Positioning System) that operates by receiving radio signals from a number of the Earth's satellites and by computing the time delay of signals received from one satellite as compared with the other. When the position of a vehicle is determined with a periodic rate, computation of its velocity is no problem. For smaller objects and shorter distances, GPS is not a solution. Detecting the velocity for such objects requires different references. A basic idea behind many sensors for the transduction of velocity or acceleration is a measurement of the displacement of an object with respect to some reference object which, in many cases, is an integral part of the sensor. *Displacement* here is a keyword. Many velocity or acceleration sensors contain components which are sensitive to a displacement. Thus, the position and displacement sensors described are the

integral parts of the velocity sensors and accelerometers. In some instances, however, velocity sensors and accelerometers do not use an intermediate displacement transducer because their motions may be directly converted into electrical signals. When specifying an accelerometer for a particular application, one should answer a number of questions:

1. What is the anticipated magnitude of vibration or linear acceleration?
2. What is the operating temperature and how fast can the ambient temperature change?
3. What is the anticipated frequency range?
4. What linearity and accuracy are required?
5. What is the maximum tolerable size?
6. What kind of power supply is available?
7. Are any corrosive chemicals or high moisture present?
8. What is an anticipated over shock?
9. Are intense acoustic, electromagnetic, or electrostatic fields present?
10. Is the machinery grounded?

1. Capacitive Accelerometers

An accelerometer requires a special component whose movement lags behind that of the accelerometer's housing, which is coupled to the object under study. Then, a displacement transducer can be employed to generate an electrical signal as a function, or proof of the acceleration. This component is usually called either a *seismic* or an *inertial* mass. Regardless of the sensors' design or the conversion technique, an ultimate goal of the measurement is the *detection of the mass displacement* with respect to the accelerometer housing. Hence, any suitable displacement transducer capable of measuring microscopic movements under strong vibrations or linear acceleration can be used in an accelerometer. A capacitive displacement conversion is one of the proven and reliable methods. A capacitive-acceleration sensor essentially contains at least two components; the first is a –stationary|| plate (i.e., connected to the housing) and the other is a plate attached to the inertial mass which is free to move inside the housing. These plates form a capacitor whose value is a function of a distance d can be used in an accelerometer. A capacitive displacement conversion is one of the proven and reliable methods. A capacitive-acceleration sensor essentially contains at least two components; the first is a –stationary|| plate (i.e., connected to the housing) and the other is a plate attached to the inertial mass which is free to move inside the housing. These plates form a capacitor whose value is a function of a distance. can be used in an accelerometer. A capacitive displacement conversion is one of the proven and reliable methods. A capacitive-acceleration sensor essentially contains at least two components; the first is a –stationary|| plate (i.e., connected to the housing) and the other is a plate attached to the inertial mass which is free to move inside the housing. These plates form a capacitor whose value is a function of a distance $20\mu\text{m}$. Hence, such a small displacement requires a reliable compensation of drifts and various interferences. This is usually accomplished by the use of a differential technique, where an additional capacitor is formed in the same structure. The value of the second capacitor must be close to that of the first, and it should be subjected to changes with a 180 degree phase shift. Then, acceleration can be represented by a difference in values between the two capacitors. Figure 7.1a shows a cross-sectional diagram of a capacitive accelerometer where an internal mass is sandwiched between the upper cap and the base. The mass is supported by four silicon springs (Fig. 7.1 b). The upper plate and the base are separated from it by respective distances d_1 , d_2 . All

three parts are micromachined from a silicon wafer. Figure 8.4 is a simplified circuit diagram for a capacitance-to-voltage converter.

A parallel-plate capacitor C_{mc} between the mass and the cap electrodes has a plate area S_1 . The plate spacing d_1 can be reduced by an amount Δ when the mass moves toward the upper plate. A second capacitor C_{mb} having a different plate area S_2 appears between the mass and the base. When mass moves toward the upper plate and away from the base, the spacing d_2 increases by Δ . The value of Δ is equal to the mechanical force F_m acting on the mass divided by the spring constant k of the silicon springs:

$$\Delta = \frac{F_m}{K}$$

Strictly speaking, the accelerometer equivalent circuit is valid only when electrostatic forces do not affect the mass position (i.e., when the capacitors depend linearly on F_m) (Fig 7.2).

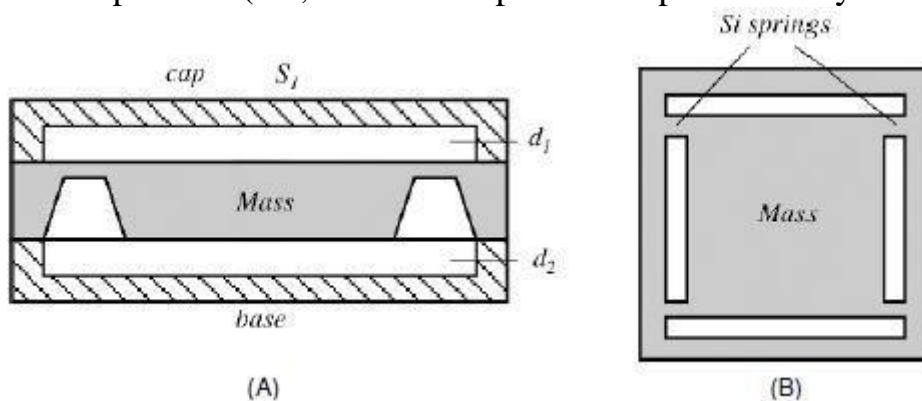

Figure (7.1): Capacitive accelerometer with a differential capacitor: (A) side cross-sectional view; (B) top view of a seismic mass supported by four silicon springs.

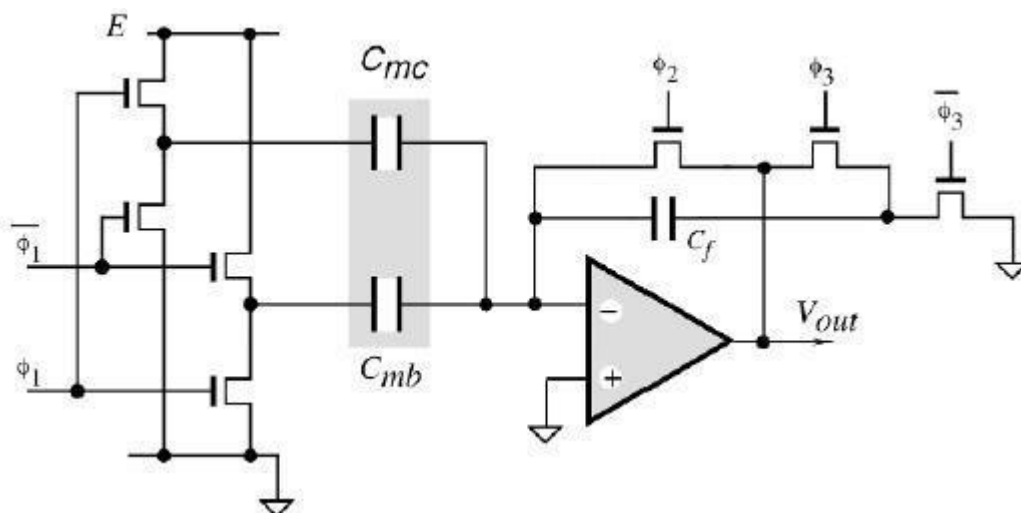

Figure (7.2): Circuit diagram of a capacitance-to-voltage conversion suitable for an integration on silicon.

When an accelerometer serves as the input capacitor to a switched capacitor summing amplifier, the output voltage depends on the value of the capacitors and, subsequently, on force:

$$V_{out} = \frac{2E(C_{mc} - C_{mb})}{C_f}$$

The accelerometer output is also a function of temperature and a capacitive mismatch. It is advisable that it be calibrated over an entire temperature range and an appropriate correction is made during the signal processing. Another effective method of assuring high stability is to design self-calibrating systems which make use of electrostatic forces appearing in the accelerometer assembly when a high voltage is applied to either a cap or base electrode.

2. Piezoresistive Accelerometers

As a sensing element, a piezoresistive accelerometer incorporates strain gauges, which measure strain in mass-supporting springs. The strain can be directly correlated with the magnitude and rate of mass displacement and, subsequently, with an acceleration. These devices can sense accelerations within a broad frequency range: from dc up to 13 kHz. With a proper design, they can withstand overshock up to 10,000 g. The overshock is a critical specification for many applications. However, piezoresistive accelerometers with discrete, epoxy-bonded strain gauges tend to have undesirable output temperature coefficients. Because they are manufactured separately, the gauges require individual thermal testing and parameter matching. This difficulty is virtually eliminated in modern sensors, which use the micromachining technology of silicon wafers.

An example of a wide-dynamic-range solid-state accelerometer is shown in Fig. 7.3. It was developed by Endevco/Allied Signal Aerospace Co. (Sunnyvale, CA). The microsensors are fabricated from three layers of silicon. The inner layer, or the core, consists of an inertial mass and the elastic hinge. The mass is suspended inside an etched rim on the hinge, which has piezoresistive gauges on either side. The gauges detect motion about the hinge. The outer two layers, the base and the lid, protect the moving parts from the external contamination. Both parts have recesses to allow the inertial mass to move freely. Several important features are incorporated into the sensor. One is that the sensitive axis lies in the plane of the silicon wafer, as opposed to many other designs where the axis is perpendicular to the wafer. Mechanical integrity and reliability are assured by the fabrication of all of the components of the sensor from a single silicon crystal.

When acceleration is applied along the sensitive axis, the inertial mass rotates around the hinge. The gauges on both sides of the hinge allow rotation of the mass to create compressive stress on one gauge and tensile on the other. Because gauges are very short, even the small displacement produces large resistance changes. To trim the zero balance of the piezoresistive bridge, there are five trimming resistors positioned on the same crystal (not shown in Fig 7.3).

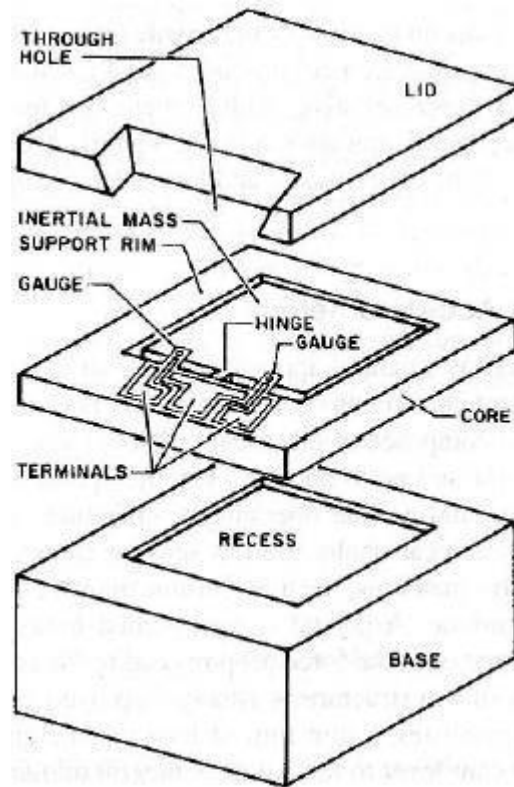

Figure (7.2): Exposed view of a piezoresistive accelerometer.

8. General Modern Applications of Sensors and Transducers

(a) Antenna

An antenna (or aerial) is a transducer designed to transmit or receive electromagnetic waves. In other words, antennas convert electromagnetic radiation into electrical current, or vice versa. Antennas generally deal in the transmission and reception of radio waves, and are a necessary part of all radio equipment. Antennas are used in systems such as radio and television broadcasting, point-to-point radio communication, wireless LAN, cell phones, radar, and spacecraft communication. Antennas are most commonly employed in air or outer space, but can also be operated under water or even through soil and rock at certain frequencies for short distances. Physically, an antenna is an arrangement of one or more conductors, usually called elements in this context. In transmission, an alternating current is created in the elements by applying a voltage at the antenna terminals, causing the elements to radiate an electromagnetic field. In reception, the inverse occurs: an electromagnetic field from another source induces an alternating current in the elements and a corresponding voltage at the antenna's terminals. Some receiving antennas (such as parabolic and horn types) incorporate shaped reflective surfaces to collect the radio waves striking them and direct or focus them onto the actual conductive elements. Some of the first rudimentary antennas were built in 1888 by Heinrich Hertz (1857–1894) in his pioneering experiments to prove the existence of electromagnetic waves predicted by the theory of James Clerk Maxwell. Hertz placed the emitter dipole in the

focal point of a parabolic reflector. He published his work and installation drawings in *Annalen der Physik und Chemie* (vol. 36, 1889).

Antennas have practical uses for the transmission and reception of radio frequency signals such as radio and television. In air, those signals travel very quickly and with a very low transmission loss. The signals are absorbed when moving through more conductive materials, such as concrete walls or rock. When encountering an interface, the waves are partially reflected and partially transmitted through. A common antenna is a vertical rod a quarter of a wavelength long. Such antennas are simple in construction, usually inexpensive, and both radiate in and receive from all horizontal directions (omnidirectional). One limitation of this antenna is that it does not radiate or receive in the direction in which the rod points. This region is called the antenna blind cone or null. There are two fundamental types of antenna directional patterns, which, with reference to a specific two dimensional plane (usually horizontal (parallel to the ground) or vertical (perpendicular to the ground)), are either:

1. Omni-directional (radiates equally in all directions), such as a vertical rod (in the horizontal plane)
2. Directional (radiates more in one direction than in the other).

In colloquial usage "omnidirectional" usually refers to all horizontal directions with reception above and below the antenna being reduced in favor of better reception (and thus range) near the horizon. A "directional" antenna usually refers to one focusing a narrow beam in a single specific direction such as a telescope or satellite dish, or, at least, focusing in a sector such as a 120° horizontal fan pattern in the case of a panel antenna at a cell site. All antennas radiate some energy in all directions in free space but careful construction results in substantial transmission of energy in a preferred direction and negligible energy radiated in other directions. By adding additional elements (such as rods, loops or plates) and carefully arranging their length, spacing, and orientation, an antenna with desired directional properties can be created. An antenna array is two or more simple antennas combined to produce a specific directional radiation pattern. In common usage an array is composed of active elements, such as a linear array of parallel dipoles fed as a "broadside array". A slightly different feed method could cause this same array of dipoles to radiate as an "end-fire array". Antenna arrays may be built up from any basic antenna type, such as dipoles, loops or slots. The directionality of the array is due to the spatial relationships and the electrical feed relationships between individual antennas. Usually all of the elements are active (electrically fed) as in the log-periodic dipole array which offers modest gain and broad bandwidth and is traditionally used for television reception. Alternatively, a superficially similar dipole array, the Yagi-Uda Antenna (often abbreviated to "Yagi"), has only one active dipole element in a chain of parasitic dipole elements, and a very different performance with high gain over a narrow bandwidth.

An active element is electrically connected to the antenna terminals leading to the receiver or transmitter, as opposed to a parasitic element that modifies the antenna pattern without being connected directly. The active element(s) couple energy between the electromagnetic wave and the antenna terminals, thus any functioning antenna has

at least one active element. A careful arrangement of parasitic elements, such as rods or coils, can improve the radiation pattern of the active element(s). Directors and reflectors are common parasitic elements. An antenna lead-in is the medium, for example, a transmission line or feed line for conveying the signal energy between the signal source or receiver and the antenna. The antenna feed refers to the components between the antenna and an amplifier. An antenna counterpoise is a structure of conductive material most closely associated with ground that may be insulated from or capacitively coupled to the natural ground. It aids in the function of the natural ground, particularly where variations (or limitations) of the characteristics of the natural ground interfere with its proper function. Such structures are usually connected to the terminal of a receiver or source opposite to the antenna terminal. An antenna component is a portion of the antenna performing a distinct function and limited for use in an antenna, as for example, a reflector, director, or active antenna. An electromagnetic wave refractor is a structure which is shaped or positioned to delay or accelerate transmitted electromagnetic waves, passing through such structure, an amount which varies over the wave front. The refractor alters the direction of propagation of the waves emitted from the structure with respect to the waves impinging on the structure. It can alternatively bring the wave to a focus or alter the wave front in other ways, such as to convert a spherical wave front to a planar wave front (or vice-versa). The velocity of the waves radiated has a component which is in the same direction (director) or in the opposite direction (reflector) as that of the velocity of the impinging wave. A director is a parasitic element, usually a metallic conductive structure, which re-radiates into free space impinging electromagnetic radiation coming from or going to the active antenna, the velocity of the re-radiated wave having a component in the direction of the velocity of the impinging wave. A reflector is a parasitic element, usually a metallic conductive structure (e.g., screen, rod or plate), which re-radiates back into free space impinging electromagnetic radiation coming from or going to the active antenna. The velocity of the returned wave has a component in a direction opposite to the direction of the velocity of the impinging wave. The reflector modifies the radiation of the active antenna. An antenna coupling network is a passive network (which may be any combination of a resistive, inductive or capacitive circuit(s)) for transmitting the signal energy between the active antenna and a source (or receiver) of such signal energy. Typically, antennas are designed to operate in a relatively narrow frequency range. The design criteria for receiving and transmitting antennas differ slightly, but generally an antenna can receive and transmit equally well. This property is called reciprocity.



Figure (8.1): Folded dipole antenna.



Figure (8.2): Yag antenna

(b) Robots

A robot is an automatically guided machine, able to do tasks on its own. Another common characteristic is that by its appearance or movements, a robot often conveys a sense that it has intent or agency of its own.

Using Sensors in robots:

Detecting and responding to light

Sight is probably the most important of all human senses. The same applies to mobile robots. Some can detect a lamp which is several meters distant, and aim themselves

towards it. Or maybe they will go in the opposite direction, to end up in the safety of a dark corner. The important feature of light is that it is detectable at a distance. This makes it ideal for long-range sensing.

One of the problems with using light sensors is that they may be confused by room lighting or sunlight. Pulsed light sources are one way out of this problem. The panel on the right lists where to look for descriptions of a range of light sensors. These references explain how to build the sensors and how to program the robot to make use of them.

Proximity

Another use for light is for proximity sensing. Proximity sensors tell the robot when it is near to, but not actually touching an object. The word ‘_object’ includes immovable objects such as walls and furniture. In proximity sensing, the source of light is not separate from the robot, but is mounted on it, often aimed in the forward direction. A light sensor detects a nearby object by detecting the light reflected back from it. If the intensity of the reflected light exceeds a certain level, the robot knows that something is there. A light detector aimed sideways can be used to keep a robot at a fixed distance from a wall. Wall-following is a common type of behaviour; it is often used by mazesolving robots. Ultra-sound is an alternative to light in proximity detection. This requires a more complicated circuit but is not subject to interference from extraneous light sources. Ultra-sonic sensors can be programmed to measure distances, which makes it possible for the robot to map its surroundings and more easily find its way about. However, although such applications are very interesting to attempt, they are not infallible!



Figure (8.3): Robot detect light

9. Summary

. The sensors had outputs of electrical signals—voltage, current, resistance, capacitance. Because the output signals are going to be used in other electronic circuitry to provide signals that can be converted to digital signals, changes must be made to the sensor output signals to adapt them to further use.

References

- *W. Altmann, "Practical Process Control for Engineers and Technicians", Newens, 2005.*
- *J.luecke, "Analog and Digital Circuits for Electronic Control System Applications", Newens, Elsevier Inc, 2005.*
- *www.wikipedia.org*
- *J.s.Wilson,edited, "Sensor Technology Hansdbook",Newens, Elsevier Inc, 2005.*